

OFFICIAL WRESTLING GUIDE 1959

Guide

WRESTLING

1959

Carl Goodwin
Colorado State College
at Greeley

STATE



Rawlings®

ATHLETIC EQUIPMENT

"The Finest In The Field!"

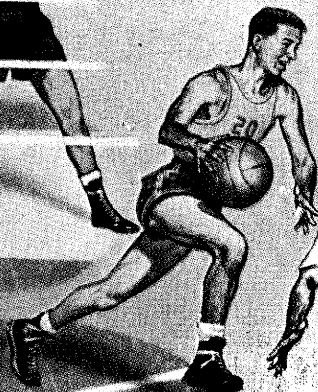
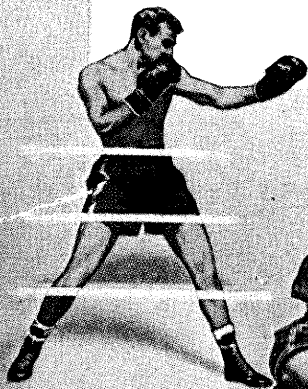

THE OFFICIAL
National Collegiate Athletic Association
WRESTLING GUIDE

The Official Rules Book
AND RECORD BOOK OF
Collegiate and Scholastic Wrestling

1959

B. R. Patterson, Editor

produced and distributed by

THE NATIONAL COLLEGIATE ATHLETIC BUREAU
NEW YORK

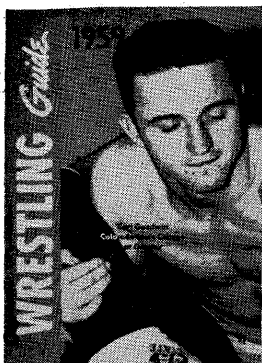

ON THE COVER: Carl Goodwin, twice 157-pound Rocky Mountain Conference champion, led the Colorado State College Bears to their 22nd consecutive RMC title last season. The 20-year-old senior, who began his mat career at West Denver High School, is majoring in industrial arts and hopes to teach in that field. Goodwin is also the Rocky Mountain 157-pound AAU titleholder.

PUBLISHED BY: The National Collegiate Athletic Association, under the supervision of its Publications Committee:

James V. Gilloon, Jr., New York U., *Chairman*
James W. Liebertz, U. S. Merchant Marine Academy
Asa S. Bushnell, Eastern College Athletic Conference

PRODUCED AND DISTRIBUTED BY: The official service organization of the NCAA, the National Collegiate Athletic Bureau:

Homer F. Cooke, Jr., *Director*

Jack Waters, *Assistant Director*

Walter Doherty, *General Editor*

Steve Boda, *Research Director*

Chris Erles, *Associate Editor*

Danny Hill, *Development Director*

Marie Montana, *Production Manager*

ADDRESS ALL CORRESPONDENCE TO: The National Collegiate Athletic Bureau, Box 757, Grand Central Station, New York 17, N. Y., on editorial and sales matters. Permission to reprint material appearing in *The NCAA Wrestling Guide*, either wholly or in part, in any form whatsoever, must be secured in writing from the publisher.

ADVERTISING REPRESENTATIVES: Spencer Advertising Company, Inc., 271 Madison Avenue, New York 16, N. Y.

COPYRIGHT, 1958, BY THE NATIONAL COLLEGIATE ATHLETIC ASSOCIATION

PRINTED IN THE UNITED STATES OF AMERICA

157-
ion,
heir
The
reer
; in
hat
ain

ate
ion

WINNER OF 10 WORLD'S FAIR GRAND PRIZES,
28 GOLD MEDALS,
HIGHEST OBSERVATORY HONORS
FOR ACCURACY

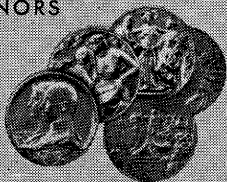
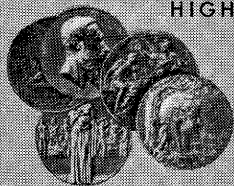

ate
ion

f

Longines

THE WORLD'S MOST HONORED WATCH

OFFICIAL WATCH FOR ALL

N. C. A. A.

CHAMPIONSHIPS

*Longines Watches are official for timing
world records for all sports throughout the world*



STANDARD OF EXCELLENCE ON FIVE CONTINENTS



This man belongs on your team . . .

You concentrate on the event. Let the Man from Capital Airlines concentrate on getting you there. He'll whisk you to that "big event" on an easy-travelin' jet-prop Viscount—5 times faster than surface transportation. No vibration. No engine roar. You relax. If you like, the Man from Capital will even make hotel reservations for your entire team. Next time you compete "away," put yourself in Capital's hands and give your team an edge before you leave the locker room.

Capital
AIRLINES

Contents

	PAGE
1958 OFFICERS OF THE NCAA	7
NATIONAL COLLEGIATE CHAMPIONSHIPS	9
<i>by Wiles Hallock</i>	
COLLEGIATE REVIEWS:	
EASTERN INTERCOLLEGIATE WRESTLING ASSOCIATION	15
<i>by George L. Shiebler</i>	
NEW ENGLAND I.W.A.	15
<i>by Lt. Darrel W. Starr, Jr.</i>	
PENNSYLVANIA TEACHERS TOURNAMENT	16
<i>by Steve Jacobs</i>	
WILKES COLLEGE OPEN TOURNAMENT	16
<i>by George Ralston</i>	
MIDDLE ATLANTIC STATES ATHLETIC CONFERENCE	17
<i>by Dick Myers</i>	
ATLANTIC COAST CONFERENCE TOURNAMENT	19
<i>by Frank W. Finger</i>	
SOUTHEASTERN INTERCOLLEGIATE CHAMPIONSHIPS	19
<i>by Swede Umbach</i>	
SOUTHERN CONFERENCE TOURNAMENT	19
MASON-DIXON TOURNAMENT	20
CIAA TOURNAMENT	20
<i>by Robert Gardner</i>	
MID-AMERICAN CONFERENCE TOURNAMENT	21
<i>by Joe Begala</i>	
MIDWEST CONFERENCE TOURNAMENT	21
<i>by Euler L. Henrickson</i>	
BIG TEN CHAMPIONSHIPS	22
<i>by Dave McCuskey</i>	
FOUR-I TOURNAMENT	22
<i>by Claude Sharer</i>	
OHIO ATHLETIC CONFERENCE	23
<i>by Al Hall</i>	
MINNESOTA STATE COLLEGE CONFERENCE	23
<i>by Robert E. Jones</i>	
COLLEGE CONFERENCE OF ILLINOIS TOURNAMENT	23
<i>by Larry Chase</i>	
BIG EIGHT CONFERENCE TOURNAMENT	25
<i>by Harry G. Burrell</i>	
ROCKY MOUNTAIN CONFERENCE TOURNAMENT	25
<i>by John W. Hancock</i>	
SKYLINE CONFERENCE TOURNAMENT	26
<i>by Allan Davis</i>	
PACIFIC COAST INTERCOLLEGIATE TOURNAMENT	26
<i>by W. M. Hammer</i>	
SOUTHERN CALIFORNIA JR. COLLEGE TOURNAMENT	26
<i>by Dave Hengsteler</i>	
N.A.I.A. TOURNAMENT	27
<i>by R. C. Macias</i>	
CANADIAN INTERCOLLEGIATE TOURNAMENT	27
<i>by Mike Yuhasz</i>	
1958 DUAL MEET RECORDS	28
SCHOLASTIC REVIEWS	31
RULES SECTION:	
MAJOR RULES CHANGES	52
NCAA WRESTLING RULES COMMITTEE	53
OFFICIAL NCAA WRESTLING RULES	54
PENALTY CHART	76
REFEREES' SIGNALS	83
SUPPLEMENTARY MODIFICATIONS FOR INTERSCHOLASTIC WRESTLING	90
INDEX TO RULES	94

SAND KNIT

Athletic Knitwear and Clothing

THE FINEST IN WRESTLING UNIFORMS

Style
No.

HELMETS

WH—Two-Way Stretch (white only)
Center Panel in School Colors.
Thick Molded Rubber Ear Protectors.
Eyelet Vents in Crown.
Lined with White Cotton Knit Cloth.

Style
No.

TRUNKS

11—Worsted Cotton Heavy Weight
12—Stretch Nylon
13—Durene
14—Cotton Heavy Weight
17—Reinforced Nylon Ribett
18—Elastex Ribett
Professional Saddle Seat
Elastic in Legs and Waist
26S—All Two-Way Stretch
27S—Reinforced Nylon Ribett

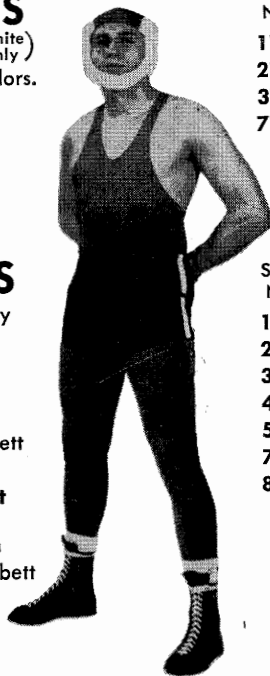

Style
No.

SHIRTS

1W—Worsted and Cotton
2W—Stretch Nylon
3W—Durene
7W—Nylon-Durene
Supporter Style Available

Style
No.

TIGHTS

1—Worsted Cotton Back
2—Stretch Nylon
3—Durene
4—Cotton Heavy Weight
5—All Two-Way Stretch
7—Reinforced Nylon Ribett
8—Elastex Ribett

**SEE YOUR SAND DEALER OR WRITE
DIRECT FOR DESCRIPTIVE FOLDER**

SAND KNITTING MILLS CORP.
BERLIN, WISCONSIN

1958 Officers of the NCAA

PRESIDENT

FRANK N. GARDNER, Drake University

SECRETARY-TREASURER

EDWIN D. MOUZON, JR., Southern Methodist University

EXECUTIVE DIRECTOR

WALTER BYERS, Fairfax Building, Kansas City, Mo.

THE COUNCIL

President and Secretary

Vice-Presidents:

- 1st District—Warren P. McGuirk, U. of Massachusetts
- 2nd District—Percy L. Sadler, Lehigh University
- 3rd District—O. K. Cornwell, U. of North Carolina
- 4th District—Harold S. Wood, Beloit College
- 5th District—Warren O. Thompson, U. of Colorado
- 6th District—Henry B. Hardt, Texas Christian U.
- 7th District—H. J. Dorricott, Colorado Western State
- 8th District—Rixford N. Snyder, Stanford University
- At-Large—Theodore Harder, Santa Barbara College

Members-at-Large:

- Col. D. S. McAlister, The Citadel
- DeLaney Kiphuth, Yale University
- H. O. Crisler, University of Michigan
- Jeremiah Ford, II, University of Pennsylvania
- Wilbur V. Hubbard, San Jose State
- F. L. Stovall, University of Houston
- E. E. Wieman, University of Denver

EXECUTIVE COMMITTEE

President, Secretary-Treasurer and Vice-President-at-Large

- Thomas D. Bolles, Harvard University
- Jefferson J. Coleman, University of Alabama
- Roy S. Keene, Oregon State College
- H. J. Dorricott, Colorado Western State
- Ralph Furey, Columbia University
- George D. Small, University of Tulsa
- Richard C. Larkins, Ohio State University

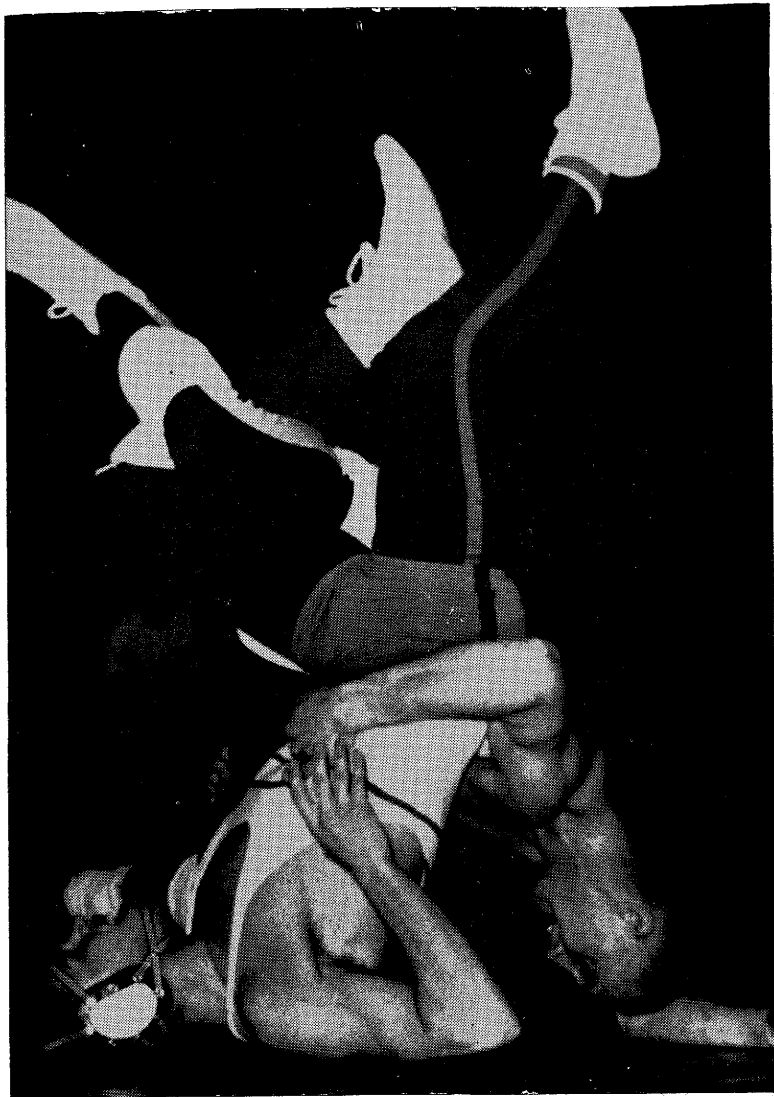

WRESTLING WITH THE PROBLEM of pinning Minnesota's Bill Wright (white jersey) is Wyoming's Dick Ballinger. Unorthodox hold didn't, but Ballinger won 167-pound quarter-final match, 8-2, to advance in 1958 National Championships.

National Collegiate Championships

By WILES HALLOCK

Athletic Publicity Director, University of Wyoming

The Cowboys of Oklahoma State University reacted violently to their one-year eviction from the throne room in 1957. Thus, in the 28th annual National Collegiate wrestling championships in Wyoming's Memorial fieldhouse, March 28 and 29, they convincingly crushed 49 other team rivals to win a fourth crown in five years with a record-breaking score of 77 points.

In reversing the order of the Big Eight conference finish, the stout Stillwater crew avenged its two-point loss to Iowa State and as added frosting to the championship cake, made coach Myron Roderick the youngest winning coach in the history of the tournament.

The Cyclones of Ames finished 15 points in arrears with 62 markers, while defending titlist Oklahoma was another 12 back at 50. Three Big Ten universities filled out the top six—Michigan State with 35, Iowa with 26, and Illinois with 22.

Going into the finals the Cowboys led the Cyclones by just one point, 28 to 27. To the uninitiated it was tighter than the 231-match schedule so efficiently ramrodded by host Wyoming. It would have taken a miracle for Iowa State because OSU had five in the championship round and three in the consolation finals. Iowa State had three-and-three and needed maximum scoring on its own part combined with the minimum on the part of Oklahoma State to win.

The Iowa State miracle didn't come off. Oklahoma State produced two champions, three runnersup, a third-place winner, and two fourth-place finishers. But Iowa State came through with two individual winners, one runnerup, one third place finisher and a pair of grapplers who were fourth. Oklahoma's defending titlists also had a pair of champions including the tourney's most outstanding matman, Dick Delgado, two-time king at 115 pounds.

Of the five defending champions who competed, only Delgado and Illinois heavy-weight Bob Norman repeated. In fact, only two 1958 titlists, Paul Aubrey, 137-pounder from Oklahoma and Iowa State's Ron Gray at 147 were among the top four in 1957.

Adding further evidence that 1958's tournament at Laramie showed little respect for the awesome reputations of past winners was the fact that Johnny Johnston, Penn State's unbeaten defending national titlist at 130, could manage only third at 123 this year and that two champions, Joe Gratto of Lehigh and Simon Roberts of Iowa, both failed to even place at 147. Gratto, who had moved up from 137, reached the semifinals but lost out to Indiana's Nick Petronka in the consolations, while Roberts was eliminated for good by Utah's Earl Dearing.

For the second year in a row, 1956 heavyweight champ Gordon Roesler of Oklahoma failed in his bid to repeat. Maidlow, the Spartans' runnerup to Norman in the Big Ten heavyweight final, wisely moved down to 191 for the Nationals and was the only finalist to pin his opponent, Colgate's Pete Newell.

Wyoming's fine sophomore Dick Ballinger gave the home folk lots to cheer about as he advanced to the finals against Murty, but he was only one of a number of surprises. Others in the Cinderella category were Colorado Western's Gene Williams and Iowa State's Frank Altman, third and fourth at 115, Bill Gabbard of Illinois, third at 157, Jim Ferguson of Michigan State, third at 167, and Kurdelmeier, the 177-pound champ, who turned the tables on his Big Ten conqueror, Tim Woodin of Michigan State.

Biggest upset according to the experts was the 11-9 defeat Aubrey handed Wilson in the 137-pound final. The latter had trimmed the former in the Big Eight final and was undefeated for the year going into the championship match.

For the first time in National tournament history, five mats were used in Wyoming's spacious fieldhouse during the first three rounds. This plus the near-perfect tournament staging kept pace with the 50 teams and 187 grapplers, but the NCAA Rules Committee has wisely decided on a three-day meet in the future—in 1959 at Iowa City and in 1960 at College Park, Md.



1958 NATIONAL INDIVIDUAL CLASS TITLISTS: Left to right, front row—Ron Gray (Iowa State), Paul Aubrey (Oklahoma), Les Anderson (Iowa State), Paul Powell (Pittsburgh), Dick Delgado (Oklahoma); back row—Bob Norman (Illinois), Ken Maidlow (Michigan State), Gary Kurdelmeier (Iowa), Duane Murty (Oklahoma State), Dick Beattie (Oklahoma State).

INDIVIDUAL CHAMPIONS AND PLACE WINNERS

Class	Champion	Second	Third	Fourth
115-lb.	Delgado (Oklahoma)	Taylor (Okla. State)	Williams (Colo. Western)	Altman (Iowa State)
123-lb.	Powell (Pittsburgh)	Herald (Okla. State)	Johnston (Penn State)	Bernard (Iowa State)
130-lb.	Anderson (Iowa State)	Pearson (Michigan)	Abel (Oklahoma)	Pierce (Okla. State)
137-lb.	Aubrey (Oklahoma)	Wilson (Okla. State)	Santoro (Lehigh)	Hammaker (Lock Haven)
147-lb.	Gray (Iowa State)	Vincent (Cornell)	Anderson (Mankato St.)	Petronka (Indiana)
157-lb.	Beattie (Okla. State)	Ketelsen (Iowa State)	Gabbard (Illinois)	Heaton (Iowa Tchrs.)
167-lb.	Murty (Okla. State)	Ballinger (Wyoming)	Ferguson (Mich. State)	Minter (Mankato St.)
177-lb.	Kurdelmeier (Iowa)	Woodin (Mich. State)	Powell (Iowa State)	Dustin (Oregon St.)
191-lb.	Maidlow (Mich. State)	Newell (Colgate)	Craig (Iowa)	Kaisy (Okla. State)
Hvywt.	Norman (Illinois)	Roesler (Oklahoma)	Lynn (Okla. State)	Brand (Nebraska)

TEAM SCORING

Oklahoma State 77, Iowa State 62, Oklahoma 50, Michigan State 35, Iowa 26, Illinois 22, Wyoming 16, Cornell 16, Pittsburgh 15, Lehigh 13, Mankato State 13, Colgate 11, Michigan 10, Iowa Teachers 8, Penn State 8, Oregon 8, Lock Haven State 7, Nebraska 7, Oregon State 7, Colorado Western 7, Colorado St. Col. 6, Maryland 6, California Poly 5, Indiana 5, Colorado 5, Minnesota 4, Utah State 3, San Jose State 3, Kansas State 3, Colorado St. U. 2, Southern Illinois 2, Springfield 2, Colorado Mines 2, Cornell Col. 1, Brigham Young 1, Kent State 1, Dartmouth 1, Portland State 1.

National Collegiate Tournament Results**115-Pound Class**

FIRST ROUND—Prunty (Minnesota) d. Shrock (Lewis & Clark) 8-2; Delgado (Oklahoma) pinned Ueyematsu (Utah State) 5:59; Altman (Iowa State) d. Shapiro (Carleton) 7-0; Guldberg (Iowa Tchrs.) d. McCall (Temple) 10-7.

QUARTER-FINAL ROUND—Williams (Colo. Western) d. Prunty 9-7; Delgado pinned Thamert (Mankato St.) 5:22; Taylor d. Altman 8-5; Osborne (Maryland) d. Guldberg 6-3.

SEMI-FINAL ROUND—Delgado pinned Williams 6:40; Taylor ref. d. Osborne 3-0.

FINAL ROUND—Delgado d. Taylor 8-3. Consolation—Williams ref. d. Altman 3-0.

123-Pound Class

PRELIMINARY—Haney (Maryland) d. Munnich (Kings Point) 4-2.

FIRST ROUND—Herald (Okla. State) d. Christie (Portland State) 10-4; Johnston (Penn State) d. Miller (Kansas State) 5-1; Haney d. Wager (Toledo) 3-2; Powell (Pittsburgh) d. Simonek (Cal Poly) 5-3; Bernard (Iowa State) d. Mueller (Minnesota) 5-2; Neuschwander (Oregon State) d. Shelton (Oklahoma) 7-4; Jordan (Colo. St. Col.) d. Auble (Cornell) 6-5.

QUARTER-FINAL ROUND—Herald d. Moser (Iowa) 4-3; Johnston d. Haney 4-2; Powell d. Bernard 7-4; Neuschwander d. Jordan 3-1.

SEMI-FINAL ROUND—Herald d. Johnston 3-2; Powell d. Neuschwander 9-4.

FINAL ROUND—Powell d. Herald 11-4. Consolation—Johnston d. Bernard 3-0.

130-Pound Class

PRELIMINARY—Kelly (Iowa) pinned Dewey (Brigham Young) 5:24; Griffith (Colo. Western) d. Cutsforth (Cornell Col.) 7-1; Pierce (Okla. State) d. Whitlatch (Illinois) 7-5.

FIRST ROUND—Madden (Wyoming) d. Stone (Wash. State) 2-0; Molino (Cornell) d. Kelly 4-1; Pearson (Michigan) d. Rogers (Colorado) 10-3; Abel (Oklahoma) d. Griffith 8-5; Pierce d. McNair (Kent State) 5-3; Anderson (Iowa State) d. Headington (Utah) 9-6; DeFelice (Pittsburgh) d. Vovos (Iowa Tchrs.) 6-4; Stroud (Mich. State) d. VanAucken (Maryland) 3-1.

QUARTER-FINAL ROUND—Molino d. Madden 9-4; Pearson d. Abel 4-0; Anderson d. Pierce 4-2; DeFelice d. Stroud 2-1.

SEMI-FINAL ROUND—Pearson d. Molino 5-1; Anderson d. DeFelice 4-2.

FINAL ROUND—Anderson d. Pearson 7-5. Consolation—Abel d. Pierce 6-4.

137-Pound Class

PRELIMINARY—Grubbs (So. Illinois) pinned Storch (Carleton) 8:48; Guccione (Penn State) d. Lloyd (Utah) 8-2; Wilson (Okla. State) d. Winder (Cornell Col.) 12-4; Santoro (Lehigh) d. Morrison (Indiana) 12-4; Aubrey (Oklahoma) d. Bauer (Portland State) 7-3.

FIRST ROUND—Corner (Iowa State) pinned Morris (Utah State) 2:49; Luttrell (Iowa) d. Grubbs 6-2; Hammaker (Lock Haven) d. Guccione 5-3; Wilson d. Lane (Iowa Tchrs.) 8-3; Santoro d. Heller (Virginia Tech) 8-1; Scott (Wyoming) ref. d. Chamberlain (Brigham Young) 3-0; Aubrey d. Mitchell (Colo. St. Col.) 5-0; Hall (Cal Poly) d. Boudreaux (Beloit) 5-1.

QUARTER-FINAL ROUND—Corner d. Luttrell 4-0; Wilson d. Hammaker 14-5; Santoro d. Scott 6-3; Aubrey d. Hall 5-3.

SEMI-FINAL ROUND—Wilson d. Corner 5-0; Aubrey d. Santoro 5-3.

FINAL ROUND—Aubrey d. Wilson 11-9. Consolation—Santoro d. Hammaker 4-3.

147-Pound Class

PRELIMINARY—Anderson (Mankato St.) d. Cooper (Okla. State) 8-5; Biondi (Maryland) ref. d. Douglas (Colo. St. Col.) 3-0; Dearing (Oregon) d. Knight (Utah) 5-1; Gratto (Lehigh) d. Reminick (Toledo) 3-0; Jones (Wyoming) d. Vandevender (Virginia Tech) 6-2; Gray (Iowa State) pinned Miller (Carleton) 8:30.

FIRST ROUND—Holzer (Illinois) d. Gregory (Oklahoma) 5-0; Vincent (Cornell) d. Anderson 7-4; Biondi d. Patten (Iowa Tchrs.) 8-7; Dearing d. Roberts (Iowa) 4-0; Gratto pinned Neville (Colorado) 7:06; Jones d. Shaw (Lock Haven) 8-4; Gray d. Miller (Carleton) 6-0; Petronka (Indiana) d. Kresge (Brigham Young) 8-2.

QUARTER-FINAL ROUND—Vincent d. Holzer 7-3; Dearing d. Biondi 3-0; Gratto d. Jones 8-4; Gray d. Petronka 3-0.

SEMI-FINAL ROUND—Vincent pinned Dearing 0:57; Gray d. Gratto 5-2.

FINAL ROUND—Gray d. Vincent 6-2. Consolation—Anderson d. Petronka 5-0.

157-Pound Class

PRELIMINARY—Heaton (Iowa Tchrs.) d. McGlothlin (Montana State) 7-3; Schiess (Utah State) default from Reiners (Knox) 1:11; Terry (Oklahoma) d. Wirtz (Colo. St. U.) 4-1; Beattie (Okla. State) d. Gleiter (So. Dakota St.) 8-0; Lampe (Colorado) pinned Halforn (Iowa) 3:24; Beaton (Oregon) d. Gass (Cornell Col.) 8-4; Doyle (Kansas State) d. Reifsteck (Minnesota) 9-5; Burger (Springfield) d. Godfrey (Utah) 3-0; Gabbard (Illinois) d. Driscoll (Lehigh) 3-2.

FIRST ROUND—Heaton d. Gray (Penn State) 5-0; Friedman (Oklahoma) d. Schiess 11-4; Terry pinned Moser (Mich. State) 2:17; Beattie d. Lampe 4-2; Beaton d. Goodwin (Colo. St. Col.) 7-4; Doyle d. Johnston (Pittsburgh) 1-0; Brownlee (Wyoming) d. Burger 3-0; Ketelsen (Iowa State) d. Gabbard 6-2.

QUARTER-FINAL ROUND—Heaton d. Friedman 4-0; Beattie d. Terry 7-3; Beaton d. Doyle 3-2; Ketelsen d. Brownlee 3-2.

SEMI-FINAL ROUND—Beattie d. Heaton 4-1; Ketelsen d. Beaton 7-1.

FINAL ROUND—Beattie ref. d. Ketelsen 1-1. Consolation—Gabbard d. Heaton 3-2.

167-Pound Class

PRELIMINARY—Swerdfeger (Colo. Mines) ref. d. Sullivan (Oklahoma); Pitzner (Dartmouth) d. Geinger (Iowa Tchrs.) 8-2; McGuire (Colo. St. Col.) d. Spagnola (San Jose St.) 4-1; Murty (Okla. State) d. Burdick (So. Illinois) 7-1.

FIRST ROUND—Ferguson (Mich. State) d. Koenig (Kent State) 2-0; Swerdfeger d. Foster (Harvard) 2-1; Ballinger (Wyoming) pinned Skirpan (Pittsburgh) 4:09; Wright (Minnesota) d. Pitzner 6-3; Watkins (Iowa State) d. McGuire 3-1; Minter d. Riehm (Iowa) 4-3; Murty d. Krupicka (Oregon) 4-2; DiMuccio (Springfield) d. Ford (Cal Poly) 3-2.

QUARTER-FINAL ROUND—Ferguson d. Swerdfeger 3-0; Ballinger d. Wright 8-2; Minter ref. d. Watkins 2-1; Murty d. DiMuccio 9-3.

SEMI-FINAL ROUND—Ballinger d. Ferguson 2-1; Murty d. Minter 4-3.

FINAL ROUND—Murty d. Ballinger 4-2. Consolation—Ferguson d. Minter 4-2.

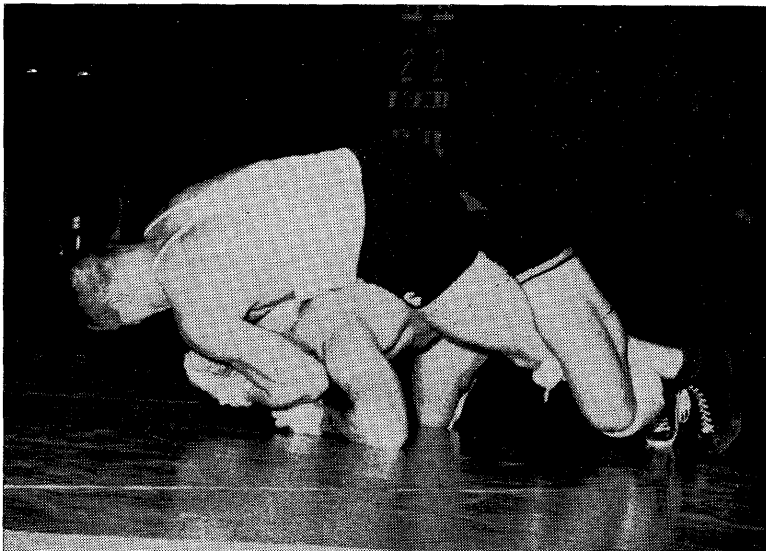

MOMENTARY ADVANTAGE—Tim Woodin of Michigan State siezes control of 177-pound National Championship match situation but Iowa's Gary Kurdelmeier rose to Spartan's challenge and grabbed title on 6-2 decision.



RETURNS TO NATIONAL THRONE—OKLAHOMA STATE: Left to right, front row—Beattie, Wilson, Pierce, Herald, Taylor; back row—Bird (trainer), Kaisy, Lynn, Nowlin, Murty, Cooper, Roderick (coach), Roberta Green (U. of Wyoming queen), Milward L. Simpson (Governor of Wyoming).

177-Pound Class

PRELIMINARY—Davidson (Lehigh) d. Payne (Utah) 10-4; Powell (Iowa State) d. Ramage (Utah State) 5-0; Camilleri (San Jose St.) d. Nowlin (Okla. State) 3-1; Benson (Lock Haven) pinned Burruss (Virginia Tech) 7:06.

FIRST ROUND—Kurdelmeier (Iowa) d. Rath (Colo. St. U.) 7-4; Miller (Cornell Col.) d. Davidson 5-4; Dean (Maryland) d. Blanshan (Mankato St.) 5-4; Powell d. Metzler (Wyoming) 8-2; Woodin (Mich. State) pinned Camilleri 5:04; Haller (Kansas State) d. Alfredson (So. Dakota St.) 5-2; Dustin (Oregon St.) d. Benson 7-3; Fiore (Kent State) d. Pepper (Colo. St. Col.) 9-2.

QUARTER-FINAL ROUND—Kurdelmeier d. Miller 7-0; Powell d. Dean 9-3; Woodin pinned Haller 3:52; Dustin d. Fiore 6-1.

SEMI-FINAL ROUND—Kurdelmeier d. Powell 6-4; Woodin d. Dustin 3-0.

FINAL ROUND—Kurdelmeier d. Woodin 6-2. Consolation—Powell d. Dustin 6-0.

191-Pound Class

PRELIMINARY—Dunlop (Cornell) pinned Jensen (So. Dakota St.) 2:32.

FIRST ROUND—Kubes (Mankato St.) d. Sullivan (Utah State) 4-1; Newell (Colgate) d. Vaughn (Colo. St. Col.) 5-2; Veldman (Minnesota) d. Brownlee (Wyoming) 4-1; Kaisy (Okla. State) d. Dunlop 8-4; Pohlman (Iowa State) d. Lee (Utah) 6-4; Adams (Colorado) d. Scales (Cal Poly) 3-2; Maidlow (Mich. State) d. White (Oklahoma) 3-0; Craig (Iowa) d. Burge (Colo. St. U.) 6-0.

QUARTER-FINAL ROUND—Newell pinned Kubes 8:58; Kaisy d. Veldman 5-1; Pohlman d. Adams 1-0; Maidlow d. Craig 3-2.

SEMI-FINAL ROUND—Newell d. Kaisy 4-0; Maidlow d. Pohlman 4-1.

FINAL ROUND—Maidlow pinned Newell 4:52. Consolation—Craig d. Kaisy 6-4.

Heavyweight Class

FIRST ROUND—Baum (Mich. State) ref. d. Lovell (Cal Poly); Lynn (Okla. State) d. Sieck (Cornell Col.) 5-3; Norman (Illinois) pinned Steinke (Utah State) 7:36; Roessler (Oklahoma) d. Bremner (Iowa) 4-3; Gotl (Colo. St. Col.) pinned Dougherty (Maryland) 5:55; Brand (Nebraska) pinned Kay (Colo. Mines) 6:53.

QUARTER-FINAL ROUND—Hanks (Brigham Young) d. Baum 5-2; Norman d. Lynn 8-3; Roessler d. Gotl 4-0; Brand pinned Nader (Kent State) 7:19.

SEMI-FINAL ROUND—Norman d. Hanks 6-2; Roessler d. Brand 2-0.

FINAL ROUND—Norman d. Roessler 5-3. Consolation—Lynn d. Brand 3-2.



CORNELL U.-COPS FIRST EASTERN CROWN SINCE 1930: Foreground—Vincent (captain); Left to right, standing—Carter, Fillius, Auble, Gardner, Molino, Dunlop, Friedman.



EASTERN INDIVIDUAL MAT CHAMPIONS: Left to right—Auble (Cornell), Johnston (Penn State), Gratto (Lehigh), Santoro (Lehigh), Johnson (Pittsburgh), Crosby (Rutgers), Davidson (Lehigh), Dunlop (Cornell).



MIDDLE ATLANTIC RULERS FOR SECOND STRAIGHT YEAR—WILKES: Left to right, front row—Williams, Thomas (co-captain), Ward (co-captain), R. Morgan; back row—Reese (coach), J. Morgan, Glogowski, Antinnes, Sishian, Gregory (mgr.).

COLLEGIATE REVIEWS

Eastern Intercollegiate Wrestling Association

By GEORGE L. SHIEBLER, *Eastern College Athletic Conference*

Cornell University tallied 64 points to capture the team title in the 54th annual Eastern Intercollegiate Wrestling Association championship tournament held at the University of Pittsburgh. The Big Red, which hadn't won an EIWA title since 1930, took two first places, three second places, and one fourth spot. Penn State, the defending champion, placed fourth.

Penn State's John Johnston, the EIWA 130-pound champion in 1956, 1957 and 1958, and 1957 national champion, was the recipient of the John A. Fletcher Memorial Trophy, awarded annually to the senior who has accumulated the most points in EIWA competition during his career. The Outstanding Wrestler award, presented each year by vote of the coaches, went to Joseph Gratto, Lehigh's 137-pound titleholder and also a 1957 national champion.

Johnston was the lone successful defending champion but David Johnson of Pittsburgh regained the 157-pound title which he won as a sophomore in 1956, becoming the Panthers' only individual champion. Johnson had won the 167-pound crown in 1957, one of three Pittsburgh victors.

Cornell's champions were David Auble and David Dunlop. Auble, an Ithaca, N. Y., sophomore, pinned Syracuse's Ed Carlin in the 123-pound final and Dunlop decisioned Anthony Stremic of Navy for the heavyweight crown.

Runner-up Lehigh's trio of individual titleholders were Gratto (137-lb.), Dick Santoro (147-lb.), and Pete Davidson in the 177-pound class.

Charles Crosby of Rutgers was the 167-pound victor, edging Bill Murphy of Syracuse in the final, 7-6, giving Rutgers its first title in six years.

The 1959 EIWA championships are scheduled for March 13 and 14 at Princeton University and in 1960 the event moves to Cornell University.

TEAM SCORING—Cornell 64, Lehigh 49, Syracuse 45, Penn State 35, Pittsburgh 27, Rutgers 22, Navy 17, Princeton 11, Pennsylvania 10, Franklin & Marshall 10, Army 8, Harvard 8, Yale 7, Brown 4, Columbia and Temple, 1 each.

Class	Champion	Second	Third	Fourth
123-lb.	Auble (Cor)	Carlin (S)	Fitch (Y)	Weinseel (A)
130-lb.	Johnston (PS)	Molino (Cor)	Creason (S)	Moyer (Pi)
137-lb.	Gratto (L)	Guccione (PS)	DeFelice (Pi)	Austin (S)
147-lb.	Santoro (L)	Vincent (Cor)	Fortenbaugh (Pr)	Yeats (FM)
157-lb.	Johnson (Pi)	Friedman (Cor)	Driscoll (L)	MacAleer (Pr)
167-lb.	Crosby (R)	Murphy (S)	Gray (PS)	Foster (Har)
177-lb.	Davidson (L)	White (S)	Garretson (R)	Gardner (Cor)
Hvywt.	Dunlop (Cor)	Stremic (N)	Traendly (Pe)	Pfrommer (FM)

New England I.W.A.

By LT. DARREL W. STARR, JR., *Coach, Coast Guard Academy*

Springfield won the New England Intercollegiate Wrestling Association championships for the eighth consecutive season, claiming five individual crowns.

Three 1957 champions successfully defended their titles, among them Burt Berger (157-lb.) of Springfield who was awarded the Coaches' Trophy as the outstanding wrestler of the tournament held at the Coast Guard Academy.

Springfield also dominated freshman competition and with all five defending

varsity champions due to return, the Maroons should provide a rather dismal picture for their opponents when they host the 1959 tournament.

TEAM SCORING—Springfield 77, Williams 59, Tufts 30, M.I.T. 20, Dartmouth 18, Coast Guard 15, Massachusetts 15, Wesleyan 14, Amherst 3.

Class	Champion	Second	Third	Fourth
123-lb.	Campana (S)	Weaver (MIT)	Matt (Wi)	Tausand (We)
130-lb.	Chassey (S)	Smith (Wi)	Simmonds (MIT)	Fiske (T)
137-lb.	Dickey (S)	Harris (M)	Danielson (A)	Wieneke (Wi)
147-lb.	Stowell (M)	Imbrie (CG)	Hutchinson (Wi)	Haney (S)
157-lb.	Burger (S)	Lewis (Wi)	Williams (T)	Graybeal (D)
167-lb.	Pitzner (D)	Noel (T)	Morgan (A)	Sorensen (We)
177-lb.	DiMuccio (S)	Bickell (D)	Moore (Wi)	Maiser (CG)
Hvywt.	Hatcher (Wi)	Fisher (T)	Jacobs (We)	Babcock (S)

Pennsylvania Teachers Tournament

By **STEVE JACOBS**, Athletic Publicity Director, Lock Haven State

Lock Haven State Teachers College not only defended its title but completely dominated the 16th annual Pennsylvania State Teachers College tournament held at Thomas Field House in Lock Haven.

The Bald Eagles rolled up 104 points, winning six individual titles for the second straight year. The victors placed seven men in the finals.

TEAM SCORING—Lock Haven 104, Millersville 71, Bloomsburg 37, West Chester 35, Shippensburg 29, Indiana 23, East Stroudsburg 15, Edinboro 8.

Class	Champion	Second	Third	Fourth
115-lb.	Bowser (S)	Foller (M)	Abrahims (LH)	Litavec (B)
123-lb.	Garman (H)	Jackson (LH)	Schultz (WC)	Sinnott (Ed)
130-lb.	Gallucci (LH)	Webb (M)	Gerstemeier (WC)	Rimple (B)
137-lb.	Hammaker (LH)	Meconi (WC)	Schaare (ES)	Yoder (Ed)
147-lb.	Clark (LH)	Mecio (M)	Lambert (WC)	Carmo (I)
157-lb.	Shaw (LH)	Rohm (B)	Doherty (M)	Knepper (S)
167-lb.	Kottmyer (M)	Ernick (I)	Stinner (LH)	Reeder (S)
177-lb.	Price (M)	Campbell (WC)	Ferguson (I)	Mumford (LH)
191-lb.	Wasilko (LH)	Baker (M)	Elinsky (B)	Gall (ES)
Hvywt.	Benson (LH)	Havice (S)	Haynes (ES)	Aikens (M)

Wilkes College Open Tournament

By **GEORGE RALSTON**

Pittsburgh won the 26th annual Wilkes College Open tournament but Cornell stole the show by winning four individual championships with its only entries.

Dave Johnson, Pitt's 167-pounder, was named the outstanding wrestler in the tourney and Richard Vincent of Cornell was high point scorer with 16.

TEAM SCORING—Pittsburgh 60, Cornell 58, Second Army 44, Army 44, Maryland 23, Michigan 22, R.I.T. 19, Lock Haven St. 18, Franklin & Marshall 13, Baltimore YMCA 13, Third Army 13, Wilkes 12, Rutgers 12, West Virginia 10, Oswego St. 10, Indiana 9, Harvard 9, Toledo 8, York YMCA 8, Temple 6, Bucknell 5, Buffalo W. C. 4, Allentown YMCA 4, Union 4, Bloomsburg St. 3, Indiana St. 3, Syracuse 3, Wesleyan 3, Wilkes-Barre YMCA 3, Winona St. 3, Ithaca 2, Lehigh 2, Lycoming 2, Muhlenberg 2, Yale 2, Waynesburg 2, Hofstra 1, Germantown YMCA 1, Notre Dame 1, Panzer 1, Springfield 1, West Chester St. 1, West Side YMCA 1.

Class	Champion	Second	Third	Fourth
115-lb.	Wilson (To)	Carey (2A)	McCall (Te)	DeLozier (WS)
123-lb.	Auble (C)	Powell (Pi)	Louchle (Pi)	Osborne (Ma)
130-lb.	Molino (C)	Rohrbach (Ma)	Van Auken (Ma)	Knepper (2A)

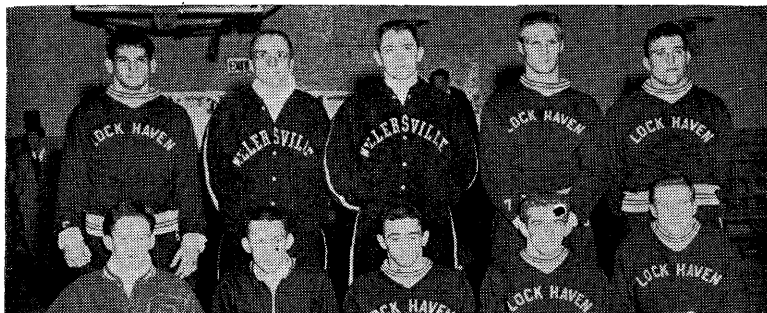

PENNSYLVANIA TEACHERS INDIVIDUAL MONARCHS: Left to right, front row—Bowser (Shippensburg), Garman (Bloomsburg), Gallucci (Lock Haven), Hammaker (Lock Haven), Clark (Lock Haven); back row—Shaw (Lock Haven), Kottmyer (Millersville), Price (Millersville), Wasilko (Lock Haven), Benson (Lock Haven).

137-lb.	DeFelice (Pi)	Grifa (R)	Zboray (In)	Ward (Wi)
147-lb.	Fornicola (2A)	Huffman (RI)	Yeats (FM)	Hammaker (LH)
157-lb.	Vincent (C)	Ruth (Le)	Turner (Le)	Nicholson (O)
167-lb.	Johnson (Pi)	DeWitt (3A)	Ellis (In)	Foster (Ha)
177-lb.	Kelly (BY)	Harvey (2A)	Skirpan (Pi)	Compliment (Pi)
191-lb.	Dunlop (C)	Zervas (Mi)	Buchanan (unatt)	Hall (Pi)
Hvywt.	Flemming (unatt)	Miller (WV)	Wasilko (LH)	Schaeffer (Le)

Middle Atlantic States Colleges Athletic Conference

By DICK MYERS, Director of Sports Publicity, Wilkes College

Wilkes College became the first team in Conference history to win the title in two successive years, amassing a total of 74 points, and placing a man among the top four in each weight class.

West Chester State, rated the most serious threat to the Colonels' crown in pre-tourney estimates, finished second with 46 points, and Muhlenberg, edged out 52-50 by Wilkes in the 1957 tourney, was third with 31.

West Chester's 177-pound entrant, Ken Campbell, annexed the tournament's Outstanding Wrestler award, gaining 15 points and winning the title on a 3:54 fall over Walt Glogowski of Wilkes.

Wilkes had five men entered in the finals, three of whom were undefeated throughout the year. The three unbeaten men, Bobby Morgan at 123, Jim Ward at 137, and Dave Thomas, 157, all won their division medals.

TEAM SCORING—Wilkes 74, West Chester 46, Muhlenberg 31, Hofstra 28, Bucknell 28, Albright 16, Lycoming 14, Ursinus 12, Lafayette 11, Swarthmore 10, Delaware 8, Moravian 8, Penn Military 8, Gettysburg 5, Elizabethtown 3, Lebanon Valley 2.

Class	Champion	Second	Third	Fourth
123-lb.	Morgan (Wi)	Mehan (S)	Schultz (WC)	Knauss (Mu)
130-lb.	Green (A)	Charles (WC)	Bifulco (H)	Williams (Wi)
137-lb.	Ward (Wi)	Romig (Ly)	Heller (H)	Bell (B)
147-lb.	Meconi (WC)	Pike (La)	Simpson (Mu)	Morgan (Wi)
157-lb.	Thomas (Wi)	Pruzman (U)	Dempster (B)	Simpson (D)
167-lb.	Murdock (B)	Antinnes (Wi)	Silvetz (Mo)	Schuman (H)
177-lb.	Campbell (WC)	Glogowski (Wi)	Martins (PM)	Keehn (Mu)
Hvywt.	Rehrig (Mu)	Bartolet (Wi)	Barnard (H)	Sislian (Wi)

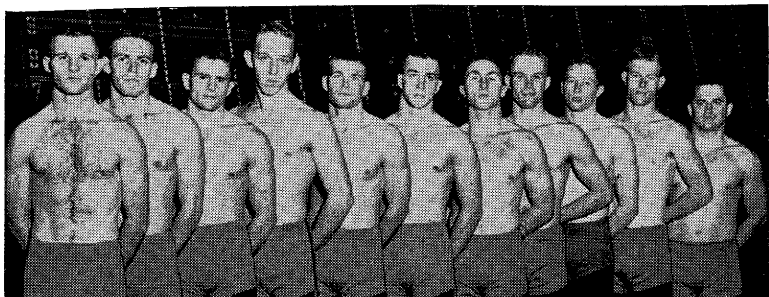

WON TWELFTH CONSECUTIVE SOUTHEASTERN TITLE—AUBURN: Left to right—McCrary, Cresap, Mason, Clinkscale, Ogburn, Bellsnyder, Kirkwood, Haugen, Greene, Branum, Tidmore.

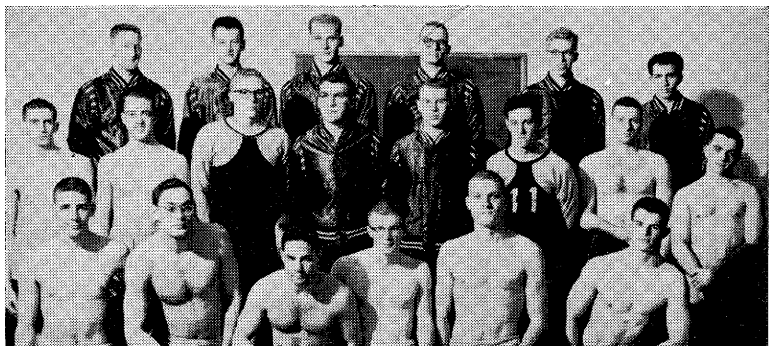

OBERLIN—OHIO CONFERENCE CO-CHAMPIONS: Left to right, front row—Mitchell, Firor, Danaceau (co-captain), Skinner (co-captain), Rugh, Clark; middle row—McKnight, Salter, Dickerson, Fehlan, Aldrich, Guthrie, Margolis, Rutsky; back row—Larrick, Kolar, Lau, Young, Lehmann (mgr.), Golden.



GAINED FIFTH STRAIGHT ACC DIADEM—MARYLAND: Left to right—Osborne, Haney, Van Auken, Santo, Biondi, Thomas, Dean, Marinelli, Dougherty.

Atlantic Coast Conference Tournament

By FRANK W. FINGER, *Coach, University of Virginia*

The championship round of the 1958 ACC tournament was virtually a re-run of the preceding year's—Maryland against the field. Of the 20 finalists, nine represented the Terrapins and five the perennial runner-up Virginia team.

The only non-Maryland champion was 157-pound Charles Gaudry of Virginia, who defeated Maryland's Dick Besnier in the semi-finals. Leading the host team to a record score were Nick Biondi (voted by the coaches the tourney's outstanding wrestler), Ray Haney and Dick Dean, all capturing their second titles.

The heavyweight crown went to Joe Dougherty in his final championship shot. Sophomore winners were Ray Osborne, who dethroned defending champion Sandy Wise, Dick VanAuken, Don Santo, Joe Thomas, and Art Marinelli. One of the departing seniors, Bill Meffert of Duke, gained his third runner-up trophy.

TEAM SCORING: Maryland 109, Virginia 63, North Carolina 39, Duke 28, Wake Forest 18, North Carolina State 0.

<i>Class</i>	<i>Champion</i>	<i>Second</i>	<i>Third</i>	<i>Fourth</i>
115-lb.	Osborne (M)	Wise (V)	Wall (NC)	_____
123-lb.	Haney (M)	Carlton (WF)	Everett (V)	Champlin (NC)
130-lb.	VanAuken (M)	Rhyne (NC)	Richey (V)	_____
137-lb.	Santo (M)	LaBone (D)	Wellborn (NC)	Shepard (V)
147-lb.	Biondi (M)	Carter (V)	Morton (WF)	Martin (D)
157-lb.	Gaudry (V)	Meffert (D)	Besnier (M)	Atkinson (NC)
167-lb.	Thomas (M)	St. Clair (V)	Menefee (D)	Russell (NC)
177-lb.	Dean (M)	Hoke (NC)	Scruggs (V)	_____
191-lb.	Marinelli (M)	Boyette (NC)	Peebles (V)	Kempler (D)
Hvywt.	Dougherty (M)	Parrott (V)	Speer (D)	Ashburn (WF)

Southeastern Intercollegiate Championships

By SWEDE UMBACH, *Coach, Auburn (Alabama Poly)*

Auburn won the Southeastern Intercollegiate Championships for the 12th consecutive year, winning seven of ten individual championships.

The meet was held at Atlanta, Ga., with Emory University the host school. Repeat winners were Gerald Cresap, Bob Mason and Arnold Haugen of Auburn.

TEAM SCORING—Auburn 94, Chattanooga 59, Sewanee 51, Emory 36, Maryville 34.

<i>Class</i>	<i>Champion</i>	<i>Second</i>	<i>Third</i>	<i>Fourth</i>
115-lb.	Harris (S)	Deloach (C)	Rumble (E)	Scott (M)
123-lb.	McCrary (A)	Wilson (E)	Stoney (S)	Johnston (M)
130-lb.	Cresap (A)	Sears (E)	Williamson (M)	_____
137-lb.	Mason (A)	Stack (C)	Conner (S)	Underwood (E)
147-lb.	Ogburn (A)	Lazell (S)	Askew (E)	Helton (C)
157-lb.	Brather (C)	Mull (M)	Kirkwood (A)	Byar (E)
167-lb.	Haugen (A)	Gee (S)	Cox (C)	Poseneeker (E)
177-lb.	Brantum (A)	Dyer (C)	Emory (M)	McKool (E)
191-lb.	Tidmore (A)	Scarritt (S)	Haushalter (C)	Huffstetler (M)
Hvywt.	Hubbert (C)	Hawkins (M)	Green (A)	Young (S)

Southern Conference Tournament

The 1958 Southern Conference Wrestling tournament, held at Virginia Military Institute, turned out to be a runaway for Virginia Tech.

Virginia Tech had four individual champions, two runner-ups and two third places to put all of its wrestlers in the scoring for a great team effort.

The Citadel was the surprising team of the tournament by finishing a strong third with six members of the team scoring.

Sherman Vandwender, 147-pound champion, was voted the tournament's outstanding wrestler. This was Vandwender's third consecutive championship.

TEAM SCORING—Virginia Tech 85, West Virginia 56, Citadel 43, Virginia Military 33, Davidson 17, Washington & Lee 17.

<i>Class</i>	<i>Champion</i>	<i>Second</i>	<i>Third</i>	<i>Fourth</i>
123-lb.	Westfall (WV)	White (VM)	Bowman (VT)	McGuckin (C)
130-lb.	Glover (VT)	Tugwell (C)	Walker (VM)	Duffield (WV)
137-lb.	Heller (VT)	Rudick (C)	Sadie (WV)	Pitard (WL)
147-lb.	Vandwender (VT)	Guidi (WV)	Kane (VM)	Pinarduck (C)
157-lb.	Westervelt (D)	Crowgey (VT)	Woodman (VM)	Dodds (WV)
167-lb.	Sherwood (WV)	Vaughn (VT)	Hollister (WL)	Pignone (C)
177-lb.	Burruss (VT)	Holland (WL)	Fagg (D)	Pledger (C)
Hvywt.	Miller (WV)	Eisenberg (C)	Oakis (VT)	Wood (VM)

Mason-Dixon Tournament

The 15th annual Mason-Dixon tournament was held at Towson State College and was won by Baltimore University which captured five individual titles.

Richard Clem of Towson State, which finished third, received the award as the outstanding wrestler in the tournament.

TEAM SCORING—Baltimore 69, Gallaudet 42, Towson State 27, Catholic U. 23, Western Maryland 18, American U. 14, Johns Hopkins 7.

<i>Class</i>	<i>Champion</i>	<i>Second</i>	<i>Third</i>	<i>Fourth</i>
123-lb.	Sugiyama (G)	Price (W)	Long (T)	French (B)
130-lb.	Marshall (B)	Gontes (C)	Johnston (G)	Kirby (T)
137-lb.	Staab (B)	Reinhart (C)	Palmer (G)	Morgan (A)
147-lb.	Frommelt (B)	Sudbrink (T)	Watson (C)	Haviston (G)
157-lb.	Sevigney (G)	Euler (W)	Pritchard (B)	Wiecek (C)
167-lb.	Calder (B)	Cohen (G)	Cock (W)	Jones (A)
177-lb.	Clem (T)	Gordon (B)	McLean (A)	Moeller (C)
Hvywt.	Kohlhafer (B)	Williams (J)	Goldschein (A)	Adams (G)

CIAA Tournament

By **ROBERT GARDNER, Coach, Lincoln University**

Virginia State College, with five champions, won the Central Intercollegiate Athletic Association tournament for the fourth consecutive year.

The outstanding wrestler award went to Charles Rodgers, Howard University's 123-pound champion.

TEAM SCORING—Virginia State 90, Morgan State 70, Lincoln University 57, Howard University 38.

<i>Class</i>	<i>Champion</i>	<i>Second</i>	<i>Third</i>	<i>Fourth</i>
115-lb.	Haines (L)	Cal'fee (V)	Jenkins (M)	Riddick (H)
123-lb.	Rodgers (H)	Holloway (V)	Harrington (M)	Humphrey (L)
130-lb.	Gilbert (M)	McMillan (H)	W. Bailey (V)	Beane (L)
137-lb.	Rice (L)	R. Bailey (V)	Baker (M)	Gee (H)
147-lb.	Norton (V)	Furgerson (M)	Hord (L)	Franklin (H)
157-lb.	Poe (V)	Chapman (H)	Rowe (M)	Kendrick (L)
167-lb.	Organ (V)	Simpson (L)	Wooden (H)	Butler (M)
177-lb.	Jones (M)	McGee (L)	Fitzgerald (V)	_____
191-lb.	Adkins (V)	Hull (M)	Wade (L)	_____
Hvywt.	Farrar (V)	Hairston (M)	Bethel (L)	_____

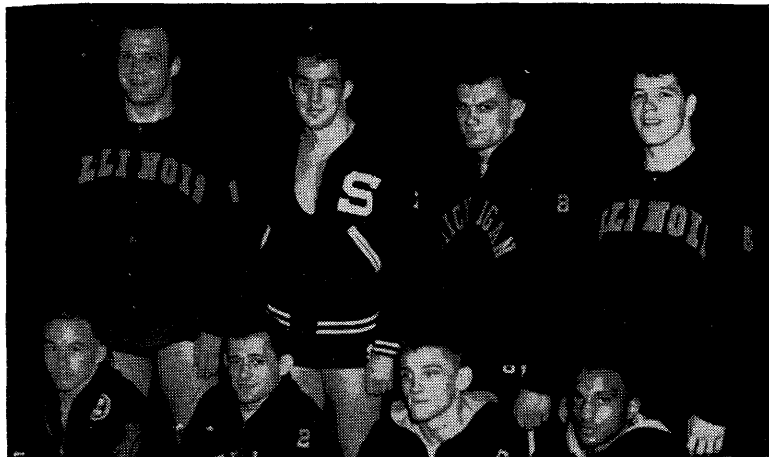

THE CLASS (CHAMPIONS) OF THE BIG TEN: Left to right, front row—Mueller (Minnesota), Pearson (Michigan), Luttrell (Iowa), Roberts (Iowa); back row—Norman (Illinois), Woodin (Michigan State), Marchello (Michigan), Holzer (Illinois).

Mid-American Conference Tournament

By JOE BEGALA

Kent State won its first conference wrestling championship since joining the M.A.C. in 1952. The big surprise of the meet was the runner-up finish of Miami which had lost several dual meets to conference schools during the season.

TEAM SCORING—Kent State 73, Miami 51, Toledo 48, Bowling Green 37, Ohio 34, Marshall 2.

Class	Champion	Second	Third	Fourth
123-lb.	Kerlin (T)	Ornowski (O)	Brodbeck (BG)	B. Thompson (Mi)
130-lb.	Fowler (Mi)	Wagner (T)	Napoli (O)	Halliwill (KS)
137-lb.	McNair (KS)	Bassett (T)	Thomas (Mi)	Adkins (Ma)
147-lb.	Remnick (T)	Semary (KS)	Dake (BG)	Evans (O)
157-lb.	Warner (Mi)	Zwolenik (O)	Kliskey (KS)	Berens (BG)
167-lb.	Koenig (KS)	Hall (Mi)	Hatfield (O)	Vance (BG)
177-lb.	Fiore (KS)	Morrill (BG)	Cameron (T)	Forth (Mi)
Hvywt.	Nader (KS)	Koeptev (BG)	Hill (Mi)	Graf (O)

Midwest Conference Tournament

By EILER L. HENRICKSON, Coach, Carleton College

Cornell regained the title which it had held for 15 consecutive seasons before losing it to Carleton last year.

The Rams had a man in either the championship or runner-up position in every division except the 123-pound class which they did not enter.

TEAM SCORING—Cornell 92, Carleton 53, Knox 43, St. Olaf 38, Grinnell 34, Coe 18, Lawrence 3, Monmouth 3, Ripon 2.

<i>Class</i>	<i>Champion</i>	<i>Second</i>	<i>Third</i>	<i>Fourth</i>
123-lb.	Cook (G)	Troutman (K)	Shapiro (Ca)	Hengl (Coe)
130-lb.	Cutsforth (Cor)	Erickson (StO)	Storch (Ca)	McCracken (Coe)
137-lb.	Winder (Cor)	Husemoller (StO)	Row (K)	Nelson (Ca)
147-lb.	Cameron (Ca)	Peterson (Cor)	Kark (StO)	Graham (M)
157-lb.	Reiners (K)	Gass (Cor)	Gibbons (Ca)	Simpson (G)
167-lb.	Anderson (Cor)	Anderson (Ca)	White (Coe)	Bauer (K)
177-lb.	Miller (Cor)	Van Anrooy (G)	Stephenson (Coe)	Williams (Ca)
191-lb.	Thronson (StO)	Stevens (Cor)	Richards (K)	Schwendler (L)
Hvywt.	Sieck (Cor)	Wilkinson (G)	Rosenberg (K)	Bonebrake (Ca)

Big Ten Championships

By **DAVE McCUSKEY**, *Coach, University of Iowa*

Iowa, with two individual champions, won the 1958 Big Ten title by the narrow margin of three points over tournament host, the University of Illinois.

Both teams were exceptionally strong and well-balanced as was the third place Michigan State squad and the defending champion, Minnesota.

Awarded the coaches' trophy as the tournament's "Most Outstanding Wrestler" was Michigan senior Max Pearson, who successfully defended his 130-pound title. Other repeat champions were Richard Mueller (123-lb.) of Minnesota, and a pair of Illini grapplers, Bob Norman (heavyweight) and Werner Holzer at 157 pounds.

TEAM SCORING—Iowa 51, Illinois 48, Michigan State 44, Minnesota 35, Michigan 28, Indiana 28, Purdue 22, Ohio State 15, Wisconsin 4, Northwestern 3.

<i>Class</i>	<i>Champion</i>	<i>Second</i>	<i>Third</i>	<i>Fourth</i>
123-lb.	Mueller (Min)	Moser (Io)	Bane (In)	Palumbo (O)
130-lb.	Pearson (Mic)	Stroud (MS)	Camaine (O)	Whitlatch (II)
137-lb.	Luttrell (Io)	Muthr (II)	Morrison (In)	Olson (W)
147-lb.	Roberts (Io)	Petronka (In)	Reifsteik (Min)	Gabbard (II)
157-lb.	Holzer (II)	Moser (MS)	Baker (Min)	Carpenter (P)
167-lb.	Marchello (Mic)	Wright (Min)	Campbell (P)	Gonino (O)
177-lb.	Woodin (MS)	Kurdelmeier (Io)	Mesec (P)	Ihnat (In)
Hvywt.	Norman (II)	Maidlow (Io)	Craig (Io)	Henley (P)

Four-I Tournament

By **CLAUDE SHARER**, *Coach, Case Tech*

The 21st annual 4-I (Interstate, Intercollegiate, Individual, Invitational) tournament attracted 127 entries from 34 colleges and universities. A team champion is not recognized at the 4-I but Kent State easily led the field.

Of the five defending champions who competed, only two repeated—Joe Ayersman of Waynesburg and Clarence McNair of Kent State.

TEAMS—Akron, Bloomsburg State, Bowling Green, Cincinnati, Colgate, Cortland State, Edinboro State, Indiana State, Ithaca, Kent State, Kings Point, Lock Haven State, Lycoming, Miami (O.), Millersville State, Notre Dame, Oswego State, Rochester Tech, Toledo, Waynesburg, Wheaton.

<i>Class</i>	<i>Champion</i>	<i>Second</i>	<i>Third</i>	<i>Fourth</i>
117-lb.	Sinnott (E)	Wager (T)	Sachel (ND)	Ridell (CS)
123-lb.	Ayersman (Wa)	Palmiere (R)	Kerlin (T)	Baski (A)
130-lb.	McNair (KS)	Munnich (KP)	Rimple (BS)	Stubber (Wh)
137-lb.	Hammaker (LH)	Semary (KS)	Romig (L)	Vega (Ci)
147-lb.	Nuss (Wh)	Reminick (T)	Huffman (R)	Carmo (IS)
157-lb.	Kottmyer (MS)	Nicholson (O)	Shaw (LH)	Wagner (M)
167-lb.	Koenig (KS)	Abraham (Wa)	Schult (Col)	Violi (I)
177-lb.	Fiore (KS)	Terembas (Wa)	Benson (LH)	Daily (A)
191-lb.	Newall (Co)	Panteley (Wa)	Wasileo (LH)	Rieder (BG)
Hvywt.	Marilla (I)	Nader (KS)	Nagurski (ND)	Stenno (T)

Ohio Athletic Conference

By **AL HALL**, *Athletic Publicity Director, University of Akron*

Akron and Oberlin were crowned co-champions as the Ohio Athletic Conference held its most successful tournament to date. Denison U. was the host school.

Bill Skinner and Hank Danaceau of Oberlin, and Walt Kohler of Hiram were the only competitors to successfully defend their titles.

TEAM SCORING—Akron and Oberlin 54, Denison 47, Ohio Wesleyan 46, Hiram 34, Kenyon 14, Muskingum 9, Wooster 4, Wittenberg 1, Capital 0.

Class	Champion	Second	Third	Fourth
123-lb.	Skinner (Ob)	Paoni (H)	Eiseman (A)	Kaplan (D)
130-lb.	Yoder (OW)	Brubach (A)	Havener (H)	Sommers (D)
137-lb.	Danaceau (Ob)	Lynch (H)	Turner (A)	Zigrossi (OW)
147-lb.	Wormald (A)	Fuller (D)	Gove (K)	Mitchell (Ob)
157-lb.	Brown (D)	Baysinger (OW)	Schori (K)	Salter (Ob)
167-lb.	Kohler (H)	Mahon (D)	Pier (A)	Currie (OW)
177-lb.	Squires (OW)	Rugh (Ob)	Sanborn (A)	Sherman (M)
Hvywt.	Daily (A)	Firor (Ob)	Wahl (OW)	Wenger (M)

Minnesota State College Conference

By **ROBERT E. JONES**, *Coach, Winona State College*

Mankato State College continued to dominate the MSCC tournament as the Indians copped seven individual championships and rolled up 101 points.

It was Mankato's third consecutive title which it won before a large audience at Winona, Minn., in a smoothly conducted tournament.

TEAM SCORING—Mankato 101, Bemidji 59, St. Cloud 42, Winona 29, Moorhead 29.

Class	Champion	Second	Third	Fourth
115-lb.	DeLozier (W)	Thamert (Ma)	Taramelli (B)	Newell (S)
123-lb.	Brines (B)	Bankole (Mo)	Lundholm (Ma)	Gabrych (W)
130-lb.	Ziska (B)	Johnson (W)	Tokay (SC)	Lasch (Mo)
137-lb.	Dravis (Ma)	Brown (B)	True (W)	Speten (S)
147-lb.	Kelly (Ma)	Sanderson (W)	Dyre (Mo)	Stein (S)
157-lb.	Anderson (Ma)	McHugh (S)	Olson (B)	Schmidt (Mo)
167-lb.	Glynn (Ma)	Anderson (S)	Wrolstad (B)	Eskelson (Mo)
177-lb.	Blanshan (Ma)	Schroedre (S)	L. Pieper (W)	Semchuk (B)
191-lb.	Minter (Ma)	Hettwer (Mo)	Marten (B)	Tucci (S)
Hvywt.	Kubes (Ma)	Johnson (B)	McHugh (S)	Tirk (Mo)

College Conference of Illinois Tournament

By **LARRY CHASE**, *Conference Publicity Director*

Wheaton won its second straight College Conference of Illinois title on the strength of five individual crowns.

Chuck Stuber, Hank Nuss and Winston Hurlburt were repeat champions for the winning Crusaders who also added a second and three third-place finishes.

The 29th annual National Collegiate Wrestling Championships will be held March 26-28, 1959, at the State University of Iowa, Iowa City, Ia.

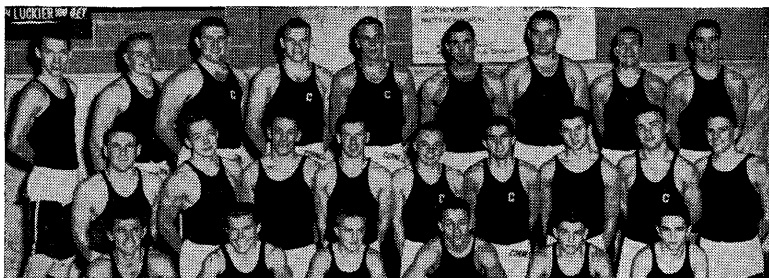

CORNELL COLLEGE—CAPTURED SIXTEENTH MIDWEST TITLE IN 17 YEARS: Left to right, front row—Gee, McClatchey, Whitmer, Cutsforth, Bey, Taylor; middle row—Platt, Tate, Dowding, Fitch, Nicholson, Winder, Lynn, Gass, Winslow; back row—Zinn, Bredehoft, Wright, Miller, Anderson, Stevens, Sieck, Corwin, Petersen.

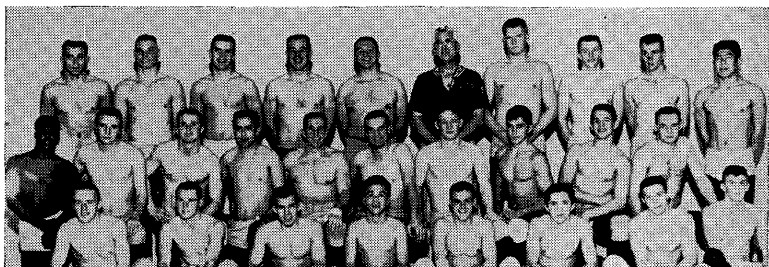

RMC RULERS FOR 22ND CONSECUTIVE SEASON—COLORADO STATE COLLEGE: Left to right, front row—Mitchell, Gomer, Thatcher, Anaya, Smith, Huff, Harden, Jordan; middle row—Douglas, Fritchel, Goodwin, Moreno, McGuire, Nichols, Humphrey, Sandelin, Wilson, Roberts; back row—Pepper, Huston, Eicher, Anderson, Trimmer, Hancock (coach), Gotti, Supanchis, Larson, Furuta.

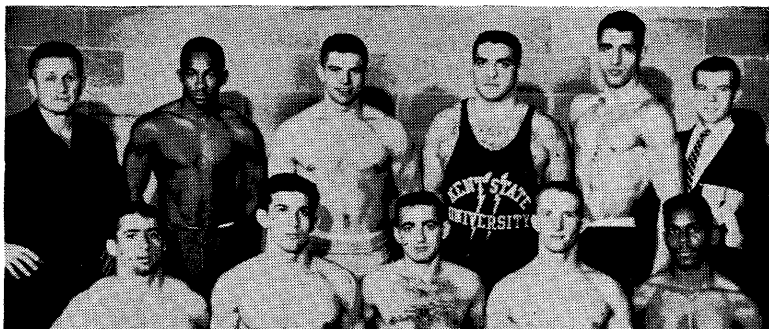

TOOK ITS FIRST MID-AMERICAN CROWN—KENT STATE: Left to right, front row—Kiskey, Searny, Russo, Hallwill, McNair; back row—Begala (coach), Jones, Koenig, Nader, Fiore, Andrik (mgr.).

TEAM SCORING—Wheaton 40, Carroll 30, Augustana 25, Lake Forest 4, Elmhurst 2.

Class	Champion	Second	Third	Fourth
123-lb.	Ferris (W)	Kitasaki (C)	Rokop (LF)	Kuester (E)
130-lb.	Hill (A)	McCormack (C)	Stoen (W)	Jorgenson (LF)
137-lb.	Stuber (W)	Boyum (A)	Behnke (C)	Patton (LF)
147-lb.	Nuss (W)	Strand (C)	LaFrenz (A)	Graves (LF)
157-lb.	Oury (W)	Mesching (C)	Williams (A)	Blom (LF)
167-lb.	Krueger (C)	Ihlefeldt (A)	Sawyer (W)	Birkner (E)
177-lb.	Jamison (A)	Templin (W)	Mulholland (E)	Keeley (C)
191-lb.	Hurlburt (W)	Stofflet (C)	Yaspelkis (A)	Wilkinson (LF)
Hvywt.	Gronewald (C)	Bryden (LF)	Marshall (W)	Anderson (A)

Big Eight Conference Tournament

By HARRY G. BURRELL, *Athletic Publicity Director, Iowa State College*

The best wrestling in the nation, the greatest conference meet—those were claims of the Big Eight wrestling experts this past year.

Oklahoma State, Iowa State and Oklahoma was the order of finish in the national championships, Iowa State first, and the other two tied for second was the conference finish.

In one of the greatest conference meets in history, the Cyclones took first place and halted the eight-year reign of the Sooners. Coach Harold Nichols' team finished only two points ahead of the two Oklahoma entries.

TEAM SCORING—Iowa State 67, Oklahoma 65, Oklahoma State 65, Kansas State 13, Colorado 11, Nebraska 7.

Class	Champion	Second	Third	Fourth
123-lb.	Delgado (O)	Herald (OS)	Altman (I)	Cervantez (K)
130-lb.	Anderson (I)	Abel (O)	Pierce (OS)	Rogers (C)
137-lb.	Wilson (OS)	Aubrey (O)	Corner (I)	Isernhagen (C)
147-lb.	Gray (I)	Williams (O)	Cooper (OS)	Baum (N)
157-lb.	Beattie (OS)	Ketelsen (I)	Lampe (C)	Terry (O)
167-lb.	Murty (OS)	Sullivan (O)	Watkins (I)	Glaze (K)
177-lb.	Powell (I)	Haller (K)	Nowlin (OS)	White (O)
Hvywt.	Roesler (O)	Pohlman (I)	Kaisy (OS)	Brand (N)

Rocky Mountain Conference Tournament

By JOHN W. HANCOCK, *Coach, Colorado State College at Greeley*

Colorado State College retained the Rocky Mountain Conference championship for the 22nd consecutive year in the tournament at Golden, Colo.

Colorado State won six individual titles but the outstanding wrestler was Glen Haase, 130-pound champion from Colorado Mines.

TEAM SCORING—Colorado State College 81, Colorado Western 56, Colorado Mines 54, Adams State 16.

Class	Champion	Second	Third	Fourth
123-lb.	Jordan (CS)	Williams (CW)	Roybal (CM)	Martinez (AS)
130-lb.	Hasse (CM)	Martinez (CW)	Harden (CS)	Gallegos (AS)
137-lb.	Griffith (CW)	Larson (CS)	Christenson (CM)	
147-lb.	Douglas (CS)	Bailey (CW)	Pinnt (CM)	Gay (AS)
157-lb.	Goodwin (CS)	Whitescarver (CM)	Hiltman (CW)	Gasca (AS)
167-lb.	McGuire (CS)	Swerdfeger (CM)	Smith (AS)	Trujillo (CW)
177-lb.	Wilson (CS)	Meyers (CM)	Allen (CW)	Madrill (AS)
Hvywt.	Goltl (CS)	Boyd (CW)	Kay (CM)	Makings (AS)

Skyline Conference Tournament

By **ALLAN DAVIS**, Coach, Brigham Young University

With five individual champions, Wyoming University again demonstrated its perennial power by taking a third consecutive Skyline Conference Championship.

Colorado State and Brigham Young fought it out for second, but Wyoming's 74 points were too much for the field.

TEAM SCORING—Wyoming 74, Colorado State U. 52, Brigham Young 47, Utah 41, Utah State 25, Denver 0, New Mexico 0.

Class	Champion	Second	Third	Fourth
123-lb.	Burtonelli (U)	Uyametso (US)	Busby (C)	French (W)
130-lb.	Madden (W)	Horiuchi (C)	Heddington (U)	Dewey (B)
137-lb.	Scott (W)	Chamberlain (B)	Lloyd (U)	Shoemaker (C)
147-lb.	Jones (W)	Kresge (B)	Smith (U)	Shreiber (US)
157-lb.	Brownlee (W)	Wirtz (O)	Francis (U)	Cooper (B)
167-lb.	Ballinger (W)	Willich (B)	Rose (C)	Payne (U)
177-lb.	Rath (C)	Ramage (US)	Lee (U)	Mutchler (W)
Hvywt.	Hanks (B)	Burge (C)	Brownlee (W)	Steinke (US)

Pacific Coast Intercollegiate Tournament

By **W. M. HAMMER**, Coach, University of Oregon

Although it notched but two individual championships, California Poly compiled 59 points, three more than runner-up Oregon and won the 1958 Pacific Coast title.

Its victory ended a three-year grip on the crown by Oregon State which fell to fourth place. Cal Poly was ninth in 1957 when its best effort was a fourth place in the 191-pound class. There were four repeat champions—Joel Neuschwander and John Dustin of Oregon State, Barry Billington of UCLA, who won his third title, and George Krupicka of Oregon who won the 157-pound title in 1956.

Tom Hall of Cal Poly won the outstanding wrestler award.

TEAM SCORING—Cal Poly 59, Oregon 56, San Jose State 45, Oregon State 43, Portland State 40, Washington State 24, UCLA 20, Lewis & Clark 13, San Diego State 13, Southern Oregon 10, Cal Aggies 5, Santa Clara 5, Oregon College 1, California 0, Washington 0.

Class	Champion	Second	Third	Fourth
115-lb.	Shrock (L)	Horiye (SD)	Tamura (OS)	Parks (O)
123-lb.	Neuschwander (OS)	Christie (P)	Simonek (CP)	Rodriguez (SJ)
130-lb.	Stone (WS)	Satchell (P)	Corcoran (CP)	Bebb (SD)
137-lb.	Hall (CP)	Bauer (P)	Roberts (SB)	Karnes (O)
147-lb.	Dearing (O)	Writ (OS)	Canfield (CP)	Cooper (P)
157-lb.	Krupicka (O)	Mall (SJ)	LeTourneau (CA)	Hoffman (P)
167-lb.	Billington (U)	Spagnola (SJ)	Meek (WS)	Beaton (O)
177-lb.	Camilleri (SJ)	Findlay (SO)	Fish (O)	Catton (U)
191-lb.	Dustin (OS)	Scales (CP)	Felix (U)	Willener (O)
Hvywt.	Lovell (CP)	Sanger (SJ)	Wheeler (O)	Rivenes (WS)

Southern California Jr. College Tournament

By **DAVE HENGSTELER**, Coach, El Camino College

In its third year of wrestling, San Bernardino Valley College dethroned Mt. San Antonio College, the defending champion, in the fifth annual Junior College Tournament, held at El Camino College.

The only repeat champion was Robert Garcia of San Bernardino in the 123-pound class. G. W. Wingo of Modesto was voted the outstanding wrestler.

TEAM SCORING—San Bernardino 55, El Camino 51, Mt. San Antonio 49, Modesto 47, Los Angeles City College 32, San Diego U. Frosh 25, Chaffey 20, Fresno 16, Orange Coast 9, Long Beach Frosh 3, Pomona Frosh 1, Antelope Valley 0.

Class	Champion	Second	Third	Fourth
123-lb.	Garcia (SB)	Fernandez (M)	Wood (EC)	Solomon (LA)
130-lb.	Kinslow (SB)	Burnett (LA)	Harris (M)	Taylor (SD)
137-lb.	Mirical (SB)	Oelkers (OC)	Rood (SD)	Mossinger (MS)
147-lb.	Coyle (EC)	Beekman (M)	Lomax (Ch)	Cunningham (F)
157-lb.	Hopping (MS)	Swallow (EC)	Carter (M)	Goodban (LB)
167-lb.	Wingo (M)	Moore (F)	Becker (SD)	Atkins (EC)
177-lb.	Hoffman (MS)	Roberts (SD)	Standrich (SB)	Strangio (M)
191-lb.	Wright (LA)	Fakhimi (Ch)	Carlson (SB)	Balown (MS)
Hvywt.	Belger (EC)	Neal (MS)	Evans (LA)	Shaw (Ch)

N.A.I.A. Tournament

By R. C. MACIAS, Coach, Mankato State College

The first NAIA tournament was won by host Mankato State as the Indians rolled up 97 points in notching five individual championships.

Al Blanshan, Mankato 177-pounder, was named the outstanding wrestler.

TEAM SCORING—Mankato State 97, Iowa Teachers 69, Northern Illinois 45, South Dakota 30, St. Cloud 20, Wartburg 19, St. John's (Minn.) 14, Winona State 14, Illinois Normal 14, Indiana Central 11, St. Thomas 10, Eastern Illinois 7, Gustavus Adolphus 7, Luther 5, Bemidji 3, Findlay 3, Moorhead 2, Stout State 2, Valley City 2, William Jewell 0, North Dakota State 0, River Falls 0, Minot 0.

Class	Champion	Second	Third	Fourth
115-lb.	Thamert (MS)	Morgan (IC)	Gulberg (IT)	Fredericks (W)
123-lb.	Tessler (NI)	DeLozzier (WS)	Sauer (StJ)	Lundholm (MS)
130-lb.	Lane (IT)	Sharp (MS)	Semetes (EI)	Chellevoid (W)
137-lb.	Vovos (IT)	Juarez (IN)	Dravis (MS)	Brown (B)
147-lb.	Anderson (MS)	Ray (IT)	Grach (NI)	Betzler (StJ)
157-lb.	Heaton (IT)	Gleiter (SDS)	Kelly (MS)	Fretheim (L)
167-lb.	Anderson (StC)	Yeinger (IT)	Young (NI)	Hess (IN)
177-lb.	Blanshan (MS)	Conrad (NI)	Alfredson (SDS)	Pieper (WS)
191-lb.	Minter (MS)	Gurtek (StT)	Jensen (SDS)	Hudson (NI)
Hvywt.	Kubes (MS)	Brye (W)	Sponberg (GA)	McHugh (StC)

Canadian Intercollegiate Tournament

By MIKE YUHASZ, Coach, University of Western Ontario

The University of Western Ontario retained its Canadian Intercollegiate Championship in the tournament held at McGill University.

All Western Ontario competitors finished among the first three places. The victors won six individual titles, a new high, and totaled 106 points. The outstanding wrestler of the tournament was Van Rappard of the Ontario Aggies, the defending 177-pound champion. Other title repeaters were Jimmy Joy of Western Ontario and Bob Heinrichs and Bob Brown of Ontario Aggies.

TEAM SCORING—Western Ontario 106, Ontario Aggies 82, Toronto 49, Queens 19, McGill 2.

Class	Champion	Runner-up	Class	Champion	Runner-up
123-lb. .	Reynolds (WO)	Reinholdt (T)	167-lb. .	Neilson (WO)	Brent (OA)
130-lb. .	Clapperton (WO)	Higgins (T)	177-lb. .	Johnson (WO)	Grunau (OA)
137-lb. .	Joy (WO)	McQuat (T)	191-lb. .	Van Rappard (OA)	Chantler (WO)
147-lb. .	Heinrich (OA)	Stuart (WO)	Hvywt. .	Brown (OA)	Sibthorp (T)
157-lb. .	Salter (WO)	Hall (OA)			

1958 Dual Meet Records

School	Coach	Record
Air Force Academy	Karl Kitt	5-7-0
Akron	Andy Maluke	8-1-0
Alfred	Alex Yunevich	4-5-0
American U.	Frank Morgan	2-4-0
Amherst	Ben McCabe	0-6-1
Appalachian State	R. W. Watkins	8-0-0
Army	Leroy Altiz	7-3-0
Auburn	Swede Umbach	8-1-0
Augustana (Ill.)	Ray Grossman	7-0-0
Baldwin-Wallace	John Summa	5-3-1
Beloit	C. Nelson-E. Wilde	3-6-0
Bemidji State	Chet Anderson	6-2-1
Bloomsburg State	Russell Houk	5-2-0
Bowling Green	Bruce Bellard	8-3-0
Brigham Young	Allan Davis	4-6-0
Brooklyn Poly	Edward Collins	6-8-0
Brown	Ralph Anderson	5-4-0
Bucknell	Bill Wrabley	7-0-0
Buffalo	George King	2-9-0
California Poly	F. S. Harden	16-0-0
Carleton	Elier Henriksen	6-3-0
Carroll (Wis.)	Mickey McCormick	8-4-1
Case Tech	Claude Sharer	5-4-1
Catholic U.	George George	2-3-0
Chattanooga	Andrew Nardo	6-1-0
Citadel	John Guiton	4-5-0
C.C.N.Y.	Joe Sapura	3-5-0
Clarkson Tech	John Hantz	2-7-0
Coast Guard	Darrel Starr, Jr.	6-2-0
Coe	Robert Liddy	2-7-0
Colgate	Harvey Potter	4-5-1
Colorado Mines	Jack Hancock	6-7-1
Colo. State Col.	John Hancock	12-2-0
Colo. State U.	Thurman McGraw	6-6-0
Colorado	Ray Jenkins	7-6-0
Colo. Western	Tracy Borah	7-4-0
Columbia	Dick Waite	2-8-1
Cornell Col.	Charles Bryant	3-4-0
Cornell U.	Eric Miller, Jr.	9-1-0
Cortland State	David Miller	5-3-1
Dartmouth	Larry Fowler	5-4-0
Davidson	Charles Parker	5-3-0
Delaware	Alden Burnham	5-3-1
Denison	Andrew Sterrett	4-6-0
Denver	Lawrence Young	0-7-1
Drexel Tech	Richard DiBattista	0-6-0
Dubuque	K. E. Mercer	5-1-0
Duke	Carmen Falcone	3-3-0
East Stroudsburg	G. Ockershausen	3-6-0
Edinboro State	Arthur McComb	4-3-0
Elmhurst	Oliver Langhorst	0-9-0
Emory	Clyde Partin	0-7-0
Findlay	Milt Cooper	5-5-1
Franklin & Marshall	Roy Phillips	5-4-0
Gallaudet	Frank Turk	6-3-0
Gettysburg		2-7-1
Ginnell	Robert Peterson	1-6-1
Gustavus Adolphus	Ade Sponberg	2-6-0
Harvard	Robert Pickett	5-4-1
Haverford	Gerald Harter	1-6-0
Hiram	Mike Koual	7-3-0
Hofstra	Walter Stone	5-6-2
Howard U.	Linwood Hardmon	0-6-0
Illinois Normal	E. L. Hill	3-4-0
Illinois Tech	Anthony Barbaro	7-2-1
Illinois	B. R. Patterson	9-2-1
Indiana	Charles McDaniel	6-4-0
Iowa State	Harold Nichols	10-0-2
Iowa Teachers	Ed Lyons	8-2-1
Iowa	David McCuskey	10-3-0
Ithaca	Herbert Broadwell	4-5-1

School	Coach	Record
Kansas State	Fritz Knorr	5-8-0
Kent State	Joseph Begala	9-0-0
Kenyon	Lester Baum	1-8-0
Kings Point	Clem Straka	11-0-1
Knox	Al Partin	8-0-0
Lafayette	Frank Eisenhower	6-3-0
Lake Forest	Al Hanke	3-9-0
Lehigh	Gerard Leeman	9-0-1
Lewis & Clark	Fred Wilson	8-5-0
Lincoln (Pa.)	Robert Gardner	3-2-1
Lock Haven State	Hubert Jack	9-3-0
Long Island Aggies	Robert Hartman	5-3-0
Luther	John Bruemmer	3-7-0
Mankato State	Rometo Macias	7-3-0
Marshall	Ed Prelaz	2-10-0
Maryland	William Krouse	6-1-2
Maryville	Marvin Mitchell	2-5-0
M.I.T.	George Myerson	0-7-0
Massachusetts	John Douglas	3-3-1
Miami (O.)	Jay Fry	5-6-0
Michigan State	Fendley Collins	3-5-0
Michigan	Clifford Keen	3-7-0
Millersville State	Theodore Rupp	7-1-0
Minnesota	Wally Johnson	8-4-0
Monmouth		1-4-2
Montana State	Keith Bowen	8-2-0
Moorhead State	Sayres Miller	3-10-0
Muhlenberg	Carl Frankett	8-2-0
Muskingum	Charles Kruzan	1-1-0
Navy Pier	Bill Mann	3-6-0
Navy	Ray Swartz	3-3-2
Nebraska	Bill Smith	1-9-0
New Mexico	Willis Barnes	0-5-1
New York U.	Carlos Henriquez	6-3-0
North Carolina State	Al Crawford	0-5-1
North Carolina	Sam Barnes	6-4-0
Northern Illinois	Robert Brigham	10-6-0
Northwestern	Ken Kraft	1-7-0
Oberlin	Thomas Jackson	4-4-0
Ohio State	Casey Fredericks	3-1-1
Ohio U.	Fred Schleicher	3-4-0
Ohio Wesleyan	Ray Leech	9-2-0
Oklahoma State	Myron Roderick	10-0-2
Oklahoma	Port Robertson	5-1-2
Ontario Aggies	Thomas Mooney	2-1-0
Oregon State	Dale Thomas	12-0-0
Oregon		6-4-0
Oswego State	Dave See	7-2-0
Penn Military	H. Sveinbjornson	5-2-0
Penn State	Charles Spidel	2-4-2
Pennsylvania	Char Bidenhour	5-4-1
Pittsburgh	Rex Peery	8-2-1
Portland State	Howard Westcott	9-4-0
Princeton	James Reed	3-4-0
Purdue	Claude Reek	2-8-0
Ripon	Ralph Erdman	2-6-1
Rochester Tech	Earl Fuller	11-2-0
Rutgers	Richard Voliva	7-2-0
St. Cloud	J. A. Mastropoalo	5-4-0
St. John's (Minn.)	Mike O'Fallon	10-1-0
St. Olaf	Charles Lunder	3-6-0
San Francisco State	Joe Verducci	1-6-0
San Jose State	Hugh Mumby	9-2-0
Saskatchewan	Don Burgess	8-4-0
Sewanee	Horace Moore	3-3-0
Shippensburg State	William Curman	2-8-0
South Dakota State	Warren Williamson	6-3-1
Southern Illinois	Bob Franz	9-0-0
Springfield	Douglas Parker	8-2-0
Stanford	Wesley Ruff	3-6-0
Swarthmore	Gomer Davies	3-4-1

INDIV
(Kent
Wayne
Fiore)

PACIFI
Hall (C
Lewis
Jose Sta

School
Syracuse
Temple
Toledo
Toronto
Tufts
U.C.L.A.
Ursinus
Utah State
Utah
Virginia M
Virginia T
Virginia T
Virginia
Wake Fore
Wartburg
Washington
Washington

Record
5-8-0
9-0-0
1-8-0
11-0-1
8-0-0
6-3-0
3-9-0
9-0-1
8-5-0
3-2-1
9-3-0
5-3-0
3-7-0
7-3-0
2-10-0
6-1-2
2-5-0
0-7-0
3-3-1
5-6-0
3-5-0
3-6-1
7-1-0
8-4-0
1-4-2
8-2-0
10-0
7-2-0
1-1-0
3-6-0
3-3-2
1-9-0
0-5-1
6-3-0
0-5-1
6-4-0
0-6-0
1-7-0
1-4-0
8-1-1
8-4-0
9-2-0
0-0-2
5-1-2
2-1-0
0-0-0
-4-0
-2-0
-2-0
-4-2
-4-1
-2-1
-4-0
-4-0
-8-0
-6-1
-2-0
-2-0
-4-0
-1-0
-6-0
-6-0
-3-0
-8-0
-3-1
10-0
-2-0
-6-0
-4-1



INDIVIDUAL 4-I KINGS: Left to right, front row—Sinnot (Edinboro State), McNair (Kent State), Kottmyer (Millersville State), Hammaker (Lock Haven State), Ayersman (Waynesburg); back row—Nuss (Wheaton), Krieger (Kent State), Marilla (Ithaca), Fiore (Kent State), Newall (Colgate).



PACIFIC COAST TITLE HOLDERS: Left to right, front row—Dearing (Oregon), Hall (Cal Poly), Stone (Washington State), Neuschwander (Oregon State), Schrock (Lewis & Clark); back row—Lovell (Cal Poly), Dustin (Oregon State), Camilleri (San Jose State), Billington (U.C.L.A.), Krupicka (Oregon).

School	Coach	Record	School	Coach	Record
Syracuse	Joseph Scandura	6-3-0	Washington	Mike Reuter	3-6-0
Temple	John Rogers	1-11-0	Waynesburg	Raymond Murdock	8-1-0
Toledo	Joe Scalzo	5-1-0	Wesleyan	Nathan Osur	3-5-0
Toronto	Jack Amos	2-6-0	Western Illinois	Harold Ave	8-1-0
Tufts	Samuel Ruggeri	4-2-2	Western Maryland	Ken Muhlhenrich	2-5-0
U.C.L.A.	George Nelson	2-4-0	Western Reserve	Edward Lewis	0-12-0
Ursinus	Kuhrt Wieneke	6-1-0	West Virginia	Steve Harrick	6-4-0
Utah State	George Nelson	4-2-0	Wheaton	Lee Pfund	11-1-0
Utah	Marvin Hess	3-5-1	Wilkes	John Reese	9-1-0
Virginia Military	Oscar Gupton	8-5-0	Williams	James Ostendarp	4-1-1
Virginia Tech	Frank Teske	6-1-0	Winona State	Bob Jones	6-3-0
Virginia	Frank Finger	5-4-0	Wisconsin	George Martin	5-6-0
Wake Forest	Don Hipps	0-7-1	Wittenberg	George Davis	1-6-0
Warburg	Norman Johansen	5-4-0	Wooster	Phil Slupe	3-5-0
Washington & Lee	Richard Miller	2-8-0	Wyoming	Everett Lantz	6-6-0
Washington State	Bill Tomaras	5-2-0	Yale	John O'Donnell	3-6-1

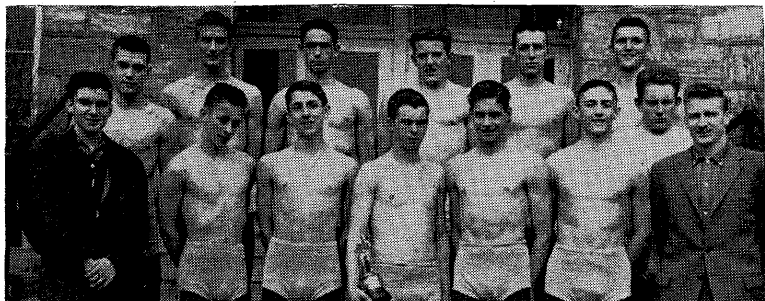

NORTH CAROLINA VICTORS—UNDEFEATED APPALACHIAN HIGH: Left to right, front row—Farthing (mgr.), Moretz, King, Critcher, Cook, Owsley, Gabriel (coach); back row—Vines, Brown, Wyke, Coleman, Norris, Edminsten, Wilson.

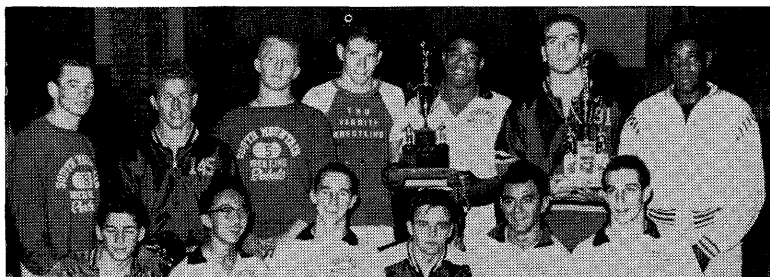

ARIZONA'S INDIVIDUAL CLASS LEADERS: Left to right, front row—Figueroa (Mesa), Tang (Phoenix Union), Daniels (Phoenix Union), McCracken (West Phoenix), Garcia (Phoenix Union), Zorbas (Phoenix Union); back row—Stites (South Mountain), Thomason (Glendale), Hanhilla (South Mountain), Benzick (Tucson), Wright (Phoenix Union), Sample (Glendale), Simpson (South Mountain).

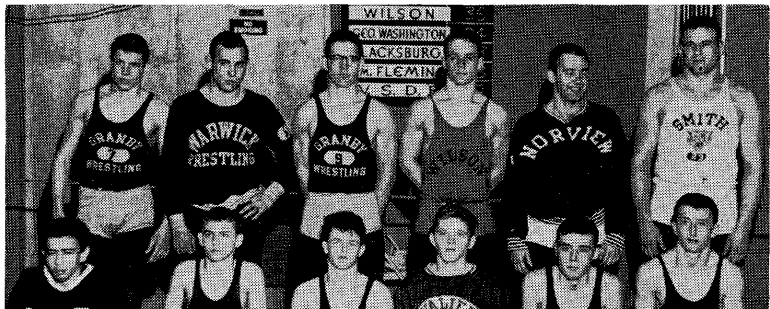

1958 VIRGINIA MAT KINGS: Left to right, front row—Seymour (Washington & Lee), Simons (Granby), Johnson (Granby), Harris (Princess Anne), Knowles (Granby), Gutmuth (Granby); back row—Langston (Granby), Bowers (Warwick), Harrison (Granby), Bartlett (Wilson), Rust (Norview), Beard (Smith).

SCHOLASTIC REVIEWS

Alabama

By **SWEDE UMBACH**, *Coach, Alabama Polytechnic Institute*

Clift High School of Opelika captured the Alabama State High School championships for the second time in the three-year history of the event. Coached by Harold Turner, Clift took six individual titles.

Benjamin Franklin of Alexander City was close behind with four class titlists and West End of Birmingham notched the other individual crown.

TEAM SCORING—Clift 102, Benjamin Russell 90, Robert E. Lee 49, Hewitt 43, West End 34, Fairfield 15, Semmes 10, Auburn 3.

<i>Class</i>	<i>Champion</i>	<i>Second</i>	<i>Third</i>	<i>Fourth</i>
103-lb.	Hamilton (C)	Tarrant (H)	Timmons (W)	Mann (B)
112-lb.	Mann (B)	Riggins (H)	Braswell (C)	Rigney (S)
120-lb.	Yates (C)	Love (B)	Willaford (H)	Saranthes (S)
127-lb.	Price (B)	Chen (R)	Dubose (C)	Hinton (S)
133-lb.	Golden (C)	Keel (B)	Hicks (W)	Vines (F)
138-lb.	Johnson (C)	Dark (B)	Wheeler (H)	Cottier (A)
145-lb.	Lee (B)	Harper (R)	Smith (C)	Head (H)
154-lb.	Dean (C)	Kyser (R)	Sillavan (W)	Franklin (H)
165-lb.	Baird (W)	Wilkes (R)	Gaston (B)	Bell (C)
175-lb.	Williams (B)	Mayfield (C)	Callaway (R)	Kelso (R)
Hvywt.	Cash (C)	Holifield (F)	Moeling (B)	Ray (W)

Arizona

By **PAT McLEAN**, *Coach, Glendale High School*

The sixth annual Arizona High School tournament was held at Glendale, Ariz., where Phoenix Union successfully defended its title.

Bobby Thomason of Glendale won his second outstanding wrestler trophy.

TEAM SCORING—Phoenix Union 112, Glendale 81, South Mountain 65, West Phoenix 55, Tucson 53, Washington 44, Catalina 38, Camelback 29, Mesa 29, Phoenix Indians 27, Pueblo 20, Yuma 20, North Phoenix 16, Sunnyslope 13, Scottsdale 6, Arizona School for Deaf 2, Carl Hayden 1.

<i>Class</i>	<i>Champion</i>	<i>Second</i>	<i>Third</i>	<i>Fourth</i>
95-lb.	Figueroa (M)	Hemetewa (PI)	Alford (Y)	Rollins (Wa)
103-lb.	Tang (PU)	Amparano (G)	Thomas (Wa)	Murphy (Cat)
112-lb.	Daniels (PU)	Tadano (G)	Rodenkirck (Su)	Hartwick (Cat)
120-lb.	McCracken (WP)	Enriquez (Wa)	Diaz (G)	Wallace (Cat)
127-lb.	Garcia (PU)	Logan (T)	Jones (SM)	Doss (NP)
133-lb.	Zorbas (PU)	Hubbard (Cam)	Muench (SM)	Turner (T)
138-lb.	Stites (SM)	Clifford (P)	Joaquin (PI)	Fuller (Cam)
145-lb.	Thomason (G)	Dunlap (PU)	Robinson (WP)	Valdez (Wa)
154-lb.	Hanhilla (SM)	Candiotte (T)	Padilla (Wa)	Dickens (Cat)
165-lb.	Benzick (T)	Clapham (G)	Rojas (PU)	Owens (M)
175-lb.	Wright (PU)	Ostland (SM)	Profiri (WP)	Rux (G)
191-lb.	Sample (G)	Burton (PU)	Gentner (T)	Halverson (WP)
Hvywt.	Simpson (SM)	Adams (PU)	Godbehere (WP)	Solley (Cat)

Northern California

By DEAN RYAN, Coach, University of California

For the second consecutive year, Madera High School, coached by Vern Brooks, won the Northern California championship. The tournament, held at the University of California, was the biggest in history with a total of 228 bouts.

Rodriguez and Marquez of Madera, Bilvado of Tulare and Marinovich of Watsonville successfully defended their titles.

TEAM SCORING—Madera 51, Fresno 47, Hayward 37, Roosevelt (Fresno) 35, Castro Valley 32, Turlock 30, Tulare 27, Camden 27, Bakersfield 24, Castlemont 22, Watsonville 21, Manteca 20, Campbell 17, Willow Glen 15, Pacifica 11, Fremont 11, Hollister 11, Pleasant Hill 10, James Lick 10, Linden 10, Corcoran 8, Livingston 7, Porterville 7, Mt. Diablo 6.

Class	Champion	Second	Third	Fourth
103-lb.	Nehring (Fres)	Garcia (R)	Finibrez (M)	Widell (W)
112-lb.	A. Rodriguez (Md)	Quintero (Tul)	Robinson (Tur)	Cardoza (Man)
120-lb.	Crouch (R)	Southwick (Man)	F. Rodriguez (M)	Davies (F)
127-lb.	Bilvado (Tul)	Stevenson (Fres)	Garcia (Ha)	Sokis (Co)
133-lb.	Marquez (Mad)	Peoples (Cas)	Raves (R)	Macias (Camd)
138-lb.	Knifer (WG)	Stroppa (Camp)	Ortega (F)	Lee (Lin)
145-lb.	Campbell (CV)	McCulley (Ho)	Williams (Camd)	Omura (Camp)
154-lb.	Paz (Ha)	Hermosillio (JL)	Tabaracci (Cas)	McBeth (CV)
165-lb.	Lopez (Ha)	Patterson (CV)	Edsell (Po)	Cariaga (Fres)
175-lb.	Hunt (B)	Felix (Pa)	Abraham (Tur)	Morrison (MD)
191-lb.	Roberts (Camd)	Ruprecht (PH)	Stiles (Tur)	Voorhees (M)
Hvywt.	Marinovich (W)	Newcomb (B)	Delgado (Frem)	Swan (Lin)

Southern California

By FRANK CROSBY

San Diego High, coached by John Lynch, won the Southern California Interscholastic Federation tournament. Mt. Miguel, in its first year of competition, turned in an outstanding performance and finished second as Southern California High School wrestling continued its rapid expansion and development.

TEAM SCORING—San Diego 56, Mt. Miguel 41, Mira Costa 38, Whittier 32, Kearney 21, Leuzinger 19, Pacific 19, Lincoln 15, Mission Bay 13, Chino 13, Harvard 13, Morning-side 12, Point Loma 12, Redondo 12, San Diego Hoover 9, Arroya Grande 9, Ramona 8, Chula Vista 6, Hawthorne 6, Torrance 6, San Diequito 5, Grossmont 4, El Cajon 4, California 4, El Rancho 3, Vista 2, Bellflower 1, Escondito 1, Helix 1.

Class	Champion	Second	Third	Fourth
95-lb.	DeGrace (MC)	Prado (W)	Davies (CV)	Longoria (SD)
103-lb.	Burnett (PL)	Haddock (M)	Logano (SD)	Christians (G)
112-lb.	Caruso (Re)	Jones (SD)	Valdez (P)	Combs (ER)
120-lb.	Andrade (W)	Kaneko (MM)	Leavy (K)	Boryla (SD)
127-lb.	Waltower (SD)	Hammond (Le)	Lain (K)	McCaw (MC)
133-lb.	Eissler (MC)	Benbow (W)	Allen (SD)	Garcia (Ca)
138-lb.	Wilkerson (Li)	Johns (MC)	Madewell (Ra)	Culwell (Le)
145-lb.	Muller (Ch)	Hulet (MM)	Kennerley (Le)	Riesgo (K)
154-lb.	Laputz (SD)	Copitas (SDH)	Guy (Haw)	Godker (EC)
165-lb.	Peterson (Har)	Hutton (MM)	Buckalew (T)	Johnson (P)
175-lb.	Osborne (MM)	Raynor (P)	Damm (K)	Rader (SD)
Hvywt.	Shea (MB)	Skaggs (AG)	Smith (SDieq)	Lolgren (M)

Colorado

By RAY JENKINS, Coach, University of Colorado

Grand Junction, coached by Carl Cox, won the Division I State High School championship. Steamboat Springs, coached by Carl Ramuno, won Division II.

This was the second year that Colorado's wrestling was divided into two divisions. Division I (schools with enrollment over 350) had 192 contestants and Division II (schools with enrollment under 350) had 96 contestants.

DIVISION I TEAM SCORING—Grand Junction 67, Montrose 62, Fruita 57, Alameda 28, Fort Morgan 25, Pueblo Central 24, Boulder 23, North Denver 23, East Denver 22, Lakewood 21, Fort Collins 18, South Denver 16, Arvada 16, Pueblo County 16, West Denver 15, Loveland 15, Grand Junction Central 15, Delta 12, Greeley 9, Lamar 9, Rocky Ford 9, Aurora 8, Colorado Springs 8, Sheridan Union 7, Englewood 5, Longmont 4, Pueblo Centennial 3, Adams City 2, Golden 1, Cortez 1, Littleton 1, Manual Denver 1, Trinidad 1, Wheatridge 1, Cherry Creek 1.

Class	Champion	Setond	Third	Fourth
95-lb.	Gonzales (GJC)	Eloe (Al)	Rhoades (GJ)	Dougherty (Au)
103-lb.	Cozzolino (PC)	Harrison (Mo)	Galves (PC)	Bennett (Fr)
112-lb.	Gonzales (GJ)	Espinoza (De)	Derig (ED)	Pacheco (CS)
120-lb.	Tisone (Bo)	Eloe (Al)	Roybal (Fr)	Nation (GJ)
127-lb.	Marez (Fr)	Peterson (GJ)	Saunders (Mo)	Barela (WD)
133-lb.	Arnold (Ar)	Henderson (Lo)	Blazer (LJ)	Flasche (Fr)
138-lb.	Gallegos (GJ)	Harrison (Mo)	Hartley (ND)	Sand (SD)
145-lb.	Graham (PC)	Griffith (FM)	Brooks (Mo)	Schroeder (La)
154-lb.	Bower (FM)	Progar (ND)	Zahourek (La)	Michie (FC)
165-lb.	Kohls (Fr)	Matlock (GJ)	Garcia (WD)	Taylor (SD)
175-lb.	Thompson (Mo)	Sago (ED)	Urquhart (Fr)	Gossart (Bo)
Hvywt.	Romig (La)	Hughes (FC)	Statt (Gr)	Price (Mo)

DIVISION II TEAM SCORING—Steamboat Springs 53, Greeley College High 33, Holyoke 31, Palisade 31, Olathe 28, Meeker 24, LaPorte 24, Fort Lupton 23, Wray 22, Mapleton 18, Rangeley 18, Center 14, Ordway 14, Brush 13, Lafayette 10, Idaho Springs 9, Florence 8, Evergreen 7, Nucla 6, Louisville 5, Manzanola 5, Hayden 4, Holly 3, Del Norte 2, Jefferson 2, Monte Vista 2, Sargent 2, Bear Creek 1, Castle Rock 1, Eads 1, Paonia 1, Yuma 1.

Class	Champion	Second	Third	Fourth
95-lb.	Bachicha (FL)	Manzanares (La)	Romer (N)	Phelps (SS)
103-lb.	Jamsey (Ma)	Chavez (O)	Guerrero (F)	Counter (FL)
112-lb.	Ybarra (B)	Fix (W)	Clubb (O)	Baylor (Man)
120-lb.	Gibbs (GCH)	Sperber (Ho)	Gerace (Ma)	Alumbaugh (Ha)
127-lb.	Carter (W)	Torres (GCH)	Reese (P)	Turner (R)
133-lb.	Barrientos (O)	Bendell (SS)	Loyd (LP)	Libsack (GCH)
138-lb.	Sandelin (SS)	Fuller (P)	Martinez (C)	Shaw (LP)
145-lb.	Dorr (SS)	Watt (M)	Logan (GCH)	Hart (LP)
154-lb.	Guire (SS)	Clapper (M)	Wood (Ho)	Land (E)
165-lb.	Turner (R)	Wood (H)	Strausser (C)	Marshall (Ho)
175-lb.	Moreland (Ord)	Vannorsdel (LP)	Sprague (Ho)	Dunn (Me)
Hvywt.	DuBose (P)	Fulton (IS)	Cruz (FL)	Beauprez (L)

Connecticut

By JOHN S. O'CONNOR, *President, C.I.W.A.*

Kent, coached by O. B. Davis, won the first annual Connecticut Interscholastic Wrestling Association tournament, held at the Kingswood School, West Hartford. **TEAM SCORING**—Kent 86, Choate 64, Kingswood 59, Pomfret 32, Wooster 18, Gunnery 16, Suffield 16, Loomis 10, Cheshire 6.

Class	Champion	Runner-up	Class	Champion	Runner-up
115-lb.	Turner (Ke)	Dolce (Ki)	147-lb.	Baiter (Ke)	Correa (W)
121-lb.	Marshall (Ki)	Cushman (Ke)	157-lb.	Ericson (Ki)	Munson (G)
127-lb.	Wells (Cho)	Terwilliger (Ki)	167-lb.	Herty (Cho)	Olmestead (P)
133-lb.	Bryant (Cho)	Ahlborn (Ke)	177-lb.	Fergusen (Ke)	Bennett (Cho)
138-lb.	Hamilton (Ke)	Longley (W)	Hvywt.	McCormick (Ki)	Walker (P)

Illinois

By OTT BAY

Waukegan Township High School, after finishing second on three previous occasions, won its first state wrestling championship. The field was very evenly balanced with four teams in contention right up to the final matches.

Some 135 teams entered the preliminary district tournaments with 64 teams

Brooks,
iversity
ovich of

esno) 35,
mont 22,
ngston 7,

W)
(Man)
F)
o)
Camd)

)
Camp)
CV)
(res)
(MD)
(M)
)

Inter-
etition,
lifornia

Kearney
orning-
mona 8,
ajon 4,

SD)
(G)

)
)
(C)
)
)

(C)

)
)
(D)

School
o II.
vo divi-
its and

qualifying boys for the final State Championship tournament. Forty-six different teams scored points in the finals.

Two defending champions were successful. Bob Evans of Waukegan retained his 127-pound crown and George Nemeth of Granite City won at 103 pounds after winning the 95-pound title in 1957.

TEAM SCORING—Waukegan 42, Tilden 38, Reavis 36, Proviso 34, Thornton 31, Blue Island 30, Granite City 30, Rock Island 30, Pekin 23, Oak Lawn 21, Evanston 19, Leyden 18, Glenbrook 17, Lyons 17, Arlington Heights 15, Danville 13, Carl Sandburg 10, Morton 9, DeKalb 8, Bloom 7, Calumet 7, Lincoln-Way 7, Lockport 7, Maine 7, Oak Park 6, Streator 5, Fenton 4, Hinsdale 4, New Trier 4, East Moline 3, Hirsch 3, Moline 3, Niles 3, Vandalia 3, Elgin 2, Elmwood Park 2, Sterling 2, Bremen 1, Campaign 1, Genesco 1, Joliet 1, Lanphier 1, Mattoon 1, Palatine 1, Roxana 1, York 1.

Class	Champion	Second	Third	Fourth
95-lb.	Thomas (Pr)	Coniglio (OL)	Weber (Gla)	Zitter (LW)
103-lb.	Nemeth (GC)	Bell (Ti)	Schmadebeck (Gle)	Keller (Mai)
112-lb.	Carlino (AH)	Allums (Ti)	Zander (Cal)	Cole (Re)
120-lb.	Parsons (Da)	Driver (Ti)	Meyers (Ly)	Wonders (Str)
127-lb.	Evans (W)	Greiner (Ev)	Weathington (BI)	Harootunium (OP)
133-lb.	Simpson (Th)	Cline (GC)	Schultz (Re)	Sheppard (Ev)
138-lb.	Moore (BI)	Temmler (Pr)	Seeley (Blo)	Sparks (GC)
145-lb.	Walt (W)	Smith (Ly)	Plapp (DK)	Rigney (Pe)
154-lb.	Benford (RI)	Graham (Pe)	Kelly (W)	Grill (Re)
165-lb.	Bruhn (Le)	Lisek (OL)	Edgerton (RI)	Reiter (Lo)
175-lb.	O'Connor (Ce)	Jacklich (CS)	White (BI)	Stone (RI)
Hvywt.	Moore (Th)	Weber (Pr)	Presern (Mor)	Wilson (F)

Indiana

By R. S. HINSHAW

The 37th annual Indiana state tournament held at Jefferson High ended in a tie between Indianapolis Broadripple and Richmond. Richmond had one first and two runner-ups while Broadripple had two individual winners.

The top five teams differed by only two points.

Bill Richardson of Lafayette Jefferson won the state crown for the third consecutive year and the outstanding wrestler award for the second time. He is undefeated in three years. Bill Andrews of Indianapolis Manual won his second title.

TEAM SCORING—Indianapolis Broadripple 25, Richmond 25, South Bend Central 24, Bloomington 23, Kokomo 23, Southport 19, Indianapolis Manual 18, Muncie Central 18, Indianapolis Washington 16, Indianapolis Shortridge 13, Lafayette Jefferson 13, Logansport 13, Crawfordsville 11, Indianapolis Technical 11, New Albany 10, Chicago Roosevelt 8, Evansville Central 8, Hammond Technical 8, Indianapolis Ben Davis 8, Mater Dei 5, LaPorte 5, Anderson 4, Hammond Clark 2, Marion 2, New Castle 2, Peru 2.

Class	Champion	Second	Third	Fourth
95-lb.	Rader (RI)	Lisembee (EC)	Shoemaker (L)	Frazier (IM)
103-lb.	Pine (K)	Helms (S)	Hutcherson (B)	Broyles (NC)
112-lb.	Clarke (B)	Black (S)	Newburn (SB)	Brooks (F)
120-lb.	Andrews (IM)	Hutcherson (B)	Kovach (R)	Collins (MC)
127-lb.	O'Dell (CV)	Lewis (R)	Kannapel (NA)	Caplin (IS)
133-lb.	Richardson (LJ)	Hettinghouse (SB)	Mahan (IM)	Ashman (S)
138-lb.	Shiple (IB)	Blackwell (S)	Bailey (LaP)	Lewis (R)
145-lb.	Campbell (MC)	Schmidt (HT)	Ramsey (NA)	Martin (IS)
154-lb.	Opp (IW)	Morris (ECR)	Carpenter (A)	Klein (IT)
165-lb.	Wells (K)	Mongan (IB)	Milatovich (IW)	Sutton (M)
175-lb.	Cox (IB)	Turner (IT)	Jones (MC)	Novotny (HC)
Hvywt.	Ellis (SB)	Thomas (L)	Meridith (MD)	Dixon (IB)

Iowa

By FINN B. ERIKSEN

This was the second consecutive year that the Iowa High School state tournament was contested in two divisions. In the class "A" division East Waterloo,

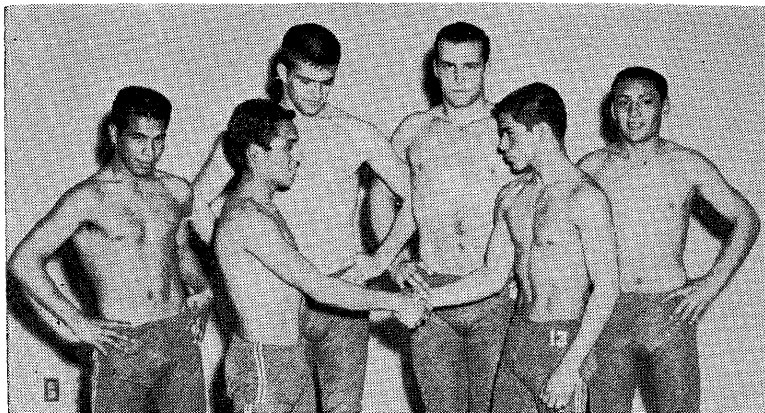

SUCCESSFULLY DEFENDS NORTHERN CALIFORNIA TITLE—MADERA HIGH: Left to right, front row—Fimbres, A. Rodriguez; back row—F. Rodriguez, McGaughey, Voorhees, Marquez.

coached by Dave Natvig, successfully defended the team championship by nosing out the city rival West Waterloo by four points.

A strong well balanced team from Cresco captured the class "B" team championship. Coach Chris Flanigan's Cresco team lost only one meet during the dual meet season, and that was to the "A" championship team from East Waterloo.

TEAM SCORING—"A" Schools: East Waterloo 54, West Waterloo 50, Fort Dodge 38, Bettendorf 26, Cedar Falls 25, Dubuque 21, Mason City 19, Decorah 18, Davenport 15, Fairfield 14, Newton 10, Clinton 10, Des Moines Tech 9, DM Lincoln 8, Charles City 6, CB Jefferson 6, CR Jefferson 5, CB Lincoln 3, DM North 3. **"B" Schools:** Cresco 68, Eagle Grove 48, Iowa Falls 26, New Hampton 24, Waverly 23, Algona 21, Osage 21, Teachers High 20, Clarion 15, Leon 14, Oelwein 14, Britt 12, DeWitt 6, Maquoketa 6, Traer 6, Manchester 5, Corning 3.

Class & Meet Champion

95-lb. A Buzzard (EW)
 95-lb. B Bernard (EG)
 103-lb. A Grandon (CF)
 103-lb. B Reed (IF)
 112-lb. A Huff (WW)
 112-lb. B Foy (B)
 120-lb. A Schnee (Du)
 120-lb. B Wilson (Cl)
 127-lb. A Hollins (EW)
 127-lb. B Gates (Cr)
 133-lb. A McElhose (WW)
 133-lb. B Flatebo (EG)
 138-lb. A Springer (WW)
 138-lb. B Bjstrom (A)
 145-lb. A Dotson (EW)
 145-lb. B Murray (Cr)
 154-lb. A Carr (EW)
 154-lb. B Grover (Cr)
 165-lb. A Church (FD)
 165-lb. B Schultz (EG)
 Hvywt. A Chuzum (F)
 Hvywt. B Wedemeier (W)

Second

Bewley (D)
 Henry (Cr)
 Gomez (B)
 Schmauss (Cr)
 Finneman (MC)
 J. Fox (Os)
 Nissen (MC)
 E. Fox (Os)
 Miller (WW)
 Betts (Oe)
 Sanford (FD)
 Briner (W)
 Natvig (De)
 Chelesvig (EG)
 Ritter (B)
 Rice (TH)
 Isaacson (Du)
 Seiler (A)
 Powers (DMT)
 Schwitters (IF)
 Thorson (FD)
 Watkins (TH)

Third

Wolverton (CRJ)
 Severson (NH)
 S'ewart (WW)
 Welch (D)
 Martinez (DML)
 Bronner (Cr)
 Klepfer (CF)
 Harman (NH)
 Geronzin (CF)
 Philip (T)
 Cranston (CF)
 Cutsforth (NH)
 Brainerd (FD)
 Burnikel (Cr)
 Blount (C)
 Walston (Man)
 Faley (N)
 Straw (NH)
 Estrem (De)
 Harris (L)
 Lehman (B)
 Clark (Oe)

Fourth

Husome (CF)
 Sebert (Cl)
 Swan (Da)
 Block (Mag)
 Mossburg (CBJ)
 Sager (Mag)
 Brown (CBT)
 Sovereign (Cr)
 Bryan (N)
 Boerjon (Os)
 Yoshida (DMN)
 Wall (IF)
 Schamerhorn, DML
 Cross (L)
 Kay (CC)
 Himmerman (Co)
 Hodge (CBL)
 Coltvet (EG)
 Brown (EW)
 Duvall (NH)
 Ward (CC)
 Stocking (L)

Kansas

By F. G. KNORR, Coach, Kansas State

Kyle Mines guided the Colby High School wrestling squad to an undefeated season, including the Western Kansas Regionals, and then won the state championship at Oakley with a team score of 55 points.

TEAM SCORING—Colby 55, St. Francis 50, Atwood 35, Goodland 33, Douglas 32, Oberlin 31, Norton 28, Wichita East 27, Salina 22, Hoxie 21, Wichita West 19, Wellington 12, Russell 11, Hutchinson 10, Oakley 7, Garden City 6, ElDorado 4.

Class	Champion	Second	Third	Fourth
98-lb.	Beltch (G)	Myers (D)	Plummer (Oa)	Taylor (N)
108-lb.	Alexander (Ob)	Newell (G)	Hamil (C)	Keller (SF)
115-lb.	Shepherd (H)	Horton (G)	Hapes (GC)	Brooks (H)
123-lb.	Krasnicka (C)	Kent (N)	Carman (SF)	Gawith (S)
130-lb.	Rath (SF)	Bird (WW)	Biggs (C)	Moser (R)
136-lb.	Duty (WE)	Stanley (D)	Mosier (H)	Schroeder (A)
141-lb.	Seay (W)	Good (S)	Bird (N)	Henry (C)
148-lb.	Little (D)	Ruda (A)	Kelly (Ob)	Metzler (C)
157-lb.	Flipse (C)	Byers (S)	Severns (N)	Howe (WE)
168-lb.	Carver (Ob)	Orth (SF)	Ruda (A)	Carpenter (ED)
175-lb.	Cooper (A)	Hull (WE)	Galyardt (R)	Williams (C)
Hvywt.	Krien (SF)	Gibbs (WW)	Bottorf (C)	Witham (H)

Maryland

By AD HAUSMANN, Chairman, M.S.A.

For the first time in its history the teams in the Maryland Scholastic Association were divided into two divisions. The winner of Division 2, Southern, defeated Gilman, the winner of Division 1, by the score of 25-9.

Southern won the Lehigh Cup and the Best Wrestler trophies were awarded to Clark Schier of McDonogh and Will Vercoe of St. Paul.

TEAM SCORING—Southern 38½, Gilman 30½, McDonogh 22½, Mervo 22, City College 20, Poly 11, Carver 10½, Dunbar 9½, St. Paul 8½, Severn 6, Patterson Park 4, Friends 2, Mt. St. Joseph 1½, Douglas ½.

Class	Champion	Second	Third	Fourth
112-lb.	Neutze (C)	Orlando (S)	Yates (McD)	Matczuk (P)
120-lb.	Hudson (S)	Decker (M)	Poole (P)	Iampieri (MSJ)
127-lb.	Schier (McD)	J. Latham (S)	Spencer-Strong (G)	Bernstein (F)
133-lb.	Doub (G)	Koch (S)	Sanders (D)	Jordan (McD)
138-lb.	Garey (S)	Burgess (P)	Waller (Car)	Sawhill (G)
145-lb.	Frick (C)	Creighton (Car)	Horner (McD)	Griswold (G)
154-lb.	Hanlin (M)	Grady (C)	Prince (D)	Callard (G)
165-lb.	Doyle (G)	Tomick (M)	Butschky (S)	Buleza (PP)
175-lb.	Vecoe (StP)	Ramsey (McD)	Marslett (M)	R. Royster (D)
Hvywt.	J. Smith (G)	MacMurray (Sev)	Lisiewski (S)	Sines (PP)

Michigan

By CLIFF KEEN

Lansing Eastern repeated as team champion, showing excellent team balance as well as having three individual champions. Lansing Sexton finishing in the runner-up spot, also displayed strong team balance and two individual titlists.

Interest in wrestling is continuing to grow in Michigan with many high schools adding this sport to their curriculum each year.

TEAM SCORING: Lansing Eastern 88, Lansing Sexton 57, Ypsilanti 43, Battle Creek 41, East Lansing 34, Hazel Park 32, Jackson 31, Adrian 22, Berkley 22, St. Thomas 17, Ann Arbor 16, Dowagiac 16, Bay City Handy 14, Willow Run 12, Kalamazoo 11, Niles 11, Royal Oak Kimball 10, Owosso 9, Farmington 7, Garden City 6, Belvidale 6, Bay City Central 5, Pontiac 5, Flint Northern 3, Michigan School for Blind 3, Allegan 2, Southfield 2, Sturgis 2, East Grand Rapids 1, Port Huron 1.

Class	Champion	Second	Third	Fourth
95-lb.	Gogarn (LE)	Black (HP)	Wilbanks (Y)	Sparks (GC)
103-lb.	Richardson (BC)	Oats (WR)	Nesbit (O)	Howard (Ka)
112-lb.	Hobbs (BC)	Surbrook (J)	Jacobs (Ad)	Hartman (LE)
120-lb.	Gautz (Ad)	Keen (AA)	Marsh (Fa)	Olson (BCH)
127-lb.	Green (EL)	Kosloski (LS)	Brown (LE)	Spenser (N)
133-lb.	Kellerman (LS)	Lett (Y)	Portt (LE)	Langenberg (BCH)
138-lb.	Hopkins (LS)	Oldham (Be)	Rapp (LE)	G. Dapprich (Y)
145-lb.	Parkinson (LE)	Litten (LS)	Reid (EL)	Downie (Be)
154-lb.	Valcanoff (LE)	W. Dapprich (Y)	Thompson (BC)	Gruhn (LS)
165-lb.	Conrad (St)	Lynch (LE)	Frudenberg (D)	Phillips (HP)
175-lb.	Rysberg (EL)	Snedden (HP)	Johnson (ROK)	Suits (AA)
Hvywt.	Young (J)	Behrman (D)	Weaver (LE)	Carli (Me)

Minnesota

By R. C. MACIAS, Coach, Mankato State College

The 22nd annual Minnesota State tournament saw Blue Earth, coached by Gene Lybbert, win its third consecutive state title.

Brad Hooper and Monte Peterson of Blue Earth, Larry Ward and Stan Christ of Mankato won their second titles and Blue Earth's Al DeLeon copped his third.

TEAM SCORING—Blue Earth 67, Mankato 50, Redwood Falls 35, Robbinsdale 31, Crosby-Ironton 31, Anoka 20, Brainerd 16, Mound 14, Vocational 14, Worthington 13, Princeton 13, St. Cloud Tech 12, Minnetonka 11, Northfield 11, Wayzata 11, Edina 10, Rochester 10, Albert Lea 8, Coleraine 8, Aitken 7, Ramsey 7, Richfield 6, Benson 6, Grand Rapids 5, Chisholm 4, Bemidji 3, Owatonna 2, St. James 2, Hutchinson 2, Hibbing 1, Tracy 1, Litchfield 1, Washburn 1, So. St. Paul 1, Cokato 1.

Class	Champion	Second	Third	Fourth
95-lb.	Erdman (Mo)	Rommel (Roc)	Leopold (RF)	Lolli (Col)
103-lb.	Sorbrook (C-I)	Breyen (An)	Thomson (Ma)	Lewis (Rob)
112-lb.	Stattler (P)	Johnson (Rob)	Corn (RF)	Hendrickson (AL)
120-lb.	Hooper (BE)	Schaber (Way)	Jordan (Br)	Zeug (RF)
127-lb.	Ward (Ma)	Olson (BE)	Parker (Br)	Bames (RF)
133-lb.	DeLeon (BE)	Rubis (An)	Lillemoen (Wo)	Tylock (E)
138-lb.	Graham (V)	Kretsch (RF)	Herrick (Ra)	Wood (C-I)
145-lb.	Peterson (BE)	D. Christ (Ma)	Casper (E)	Johnson (Ch)
154-lb.	Weihrauch (StC)	Lewis (Ma)	Berens (Ben)	Knick (Ri)
165-lb.	Hook (Rob)	Sohn (BE)	Nellis (GR)	Bailey (Ai)
175-lb.	S. Christ (Ma)	Ramstad (Mi)	Brooke (AL)	Frisbie (BE)
Hvywt.	DeCent (C-I)	Kubes (N)	Morgan (Rob)	Prins (Wo)

Missouri

By MORRIS BLITZ

The 1958 wrestling tournament had an increase in teams entered, twenty-four, and participants, two hundred and fifty-one.

Nevertheless, the reign of Ritenour High School under coach John Moore continued, as it won its eleventh straight Missouri state championship.

TEAM SCORING—Ritenour 120, Webster Groves 86, Missouri School for Blind 73, Normandy 65, Ferguson 56, Riverview Gardens 43, Maplewood 42, Lindbergh 34, Hazelwood 24, Laude 23, Kirkwood 21, O'Fallon 16, Clayton 13, University City 13, Kemper Military Academy 10, Parkway 10, Missouri Military Academy 9, Afton 5, Jennings 5, St. Louis University High 4, Vashon 4, Wentworth Military Academy 4, St. Charles 3, Bishop Du Bourg 2.

<i>Class</i>	<i>Champion</i>	<i>Second</i>	<i>Third</i>	<i>Fourth</i>
95-lb.	Simmons (WG)	Kirk (H)	Schrempf (Li)	Smith (La)
103-lb.	Nieder (MRH)	Donahue (R)	Hayes (KMA)	Nichols (F)
112-lb.	Barnes (N)	Ogle (C)	LeVan (RG)	Holmes (R)
120-lb.	Lauer (MSB)	Bayliss (R)	Tharenos (N)	Repp (F)
127-lb.	Townsend (WG)	Pierce (K)	Paul (R)	Vogel (N)
133-lb.	Sykes (MSB)	Diedrich (RG)	Stewart (WG)	Klein (La)
138-lb.	Kuntz (R)	Meyer (N)	Dickerson (OF)	Dinwiddie (MSB)
145-lb.	Duciaome (MSB)	Compton (R)	Beattie (F)	Stone (MMA)
154-lb.	Johnson (R)	Thaman (MRH)	Huddleston (H)	Brown (MSB)
165-lb.	Hooqboom (WG)	Weber (RG)	Wagner (R)	Adams (MSB)
175-lb.	Aubuchon (F)	Seaton (N)	Hartzell (R)	Fitzgerald (MRH)
Hvywt.	Brown (WG)	McGavock (R)	Viehmann (N)	Follmer (Li)

Montana

By **JUG BECK**, *Missoula County High School*

The host school, Missoula, successfully defended its Montana state championship, winning six individual championships.

Elvan Pasha of Bozeman and Missoula's Foust twins, Terry and Ted, were repeat champions. Jim Miller, Kalispell's 145-pound champion won the quick fall trophy with a 26 second fall. Terry Foust, undefeated in his high school career and three-time champion, was voted the outstanding wrestler in the tourney.

TEAM SCORING—Missoula 119, Great Falls 105, Kalispell 92, Bozeman 67, Custer 28, Billings 20, Columbia Falls 19, Helena 14, Butte Central 10, Havre 10, Glasgow 7, Polson 2, Noxon 0.

<i>Class</i>	<i>Champion</i>	<i>Second</i>	<i>Third</i>	<i>Fourth</i>
95-lb.	Cates (M)	Hughes (Bob)	T. Dailey (GF)	Patterson (Bi)
103-lb.	Lee (K)	Quickenden (GF)	Kotila (M)	Mulcahy (GF)
112-lb.	Pasha (Bo)	Kirkland (M)	Merro (K)	Bousliman (CF)
120-lb.	Poucher (GF)	Indreland (M)	Heggen (K)	Orested (C)
127-lb.	Ted Foust (M)	Thompson (Bi)	Pankratz (GF)	McGovern (BC)
133-lb.	Terry Foust (M)	J. Dailey (GF)	Stoecker (Bo)	Olson (K)
138-lb.	Felde (M)	Zadic (GF)	Hart (Bo)	Reynolds (K)
145-lb.	Miller (K)	Golden (M)	Menti (GF)	Ochsner (C)
154-lb.	Hall (GF)	Green (C)	Rogers (Bo)	Allen (CF)
165-lb.	D. Russell (M)	Dennis (K)	Blackwood (Bo)	McClave (GF)
177-lb.	B. Russell (M)	Townsend (Bo)	Johnson (GF)	Price (He)
Hvywt.	Castle (GF)	Baker (K)	Brendgard (Ha)	Carson (G)

Nebraska

By **WILLIAM SMITH**

Omaha South, with 103 points, won the 1958 Nebraska state title. The tournament was held at Lincoln High and was one of the best run events since wrestling began. Seventeen schools and a record number of 160 entries participated.

Richard Brown of South High repeated as state champion for the third time and pinned a former two-time state champion in the finals.

TEAM SCORING—Omaha South 103, Omaha Central 89, Lincoln 71, Omaha North 63, Boys Town 53, Bellevue 43, Grand Island 28, Omaha Tech 27, Lincoln Southeast 23, Lincoln Northeast 9, Nebraska Blind 8, Fremont 7, Curtis 3, Mitchell 2, Kearney 2.

<i>Class</i>	<i>Champion</i>	<i>Second</i>	<i>Third</i>	<i>Fourth</i>
95-lb.	Alexander (OS)	Jett (L)	Ottman (GI)	Schaller (B)
103-lb.	Prokupek (OS)	Fletcher (GI)	Parsons (L)	Charley (B)
112-lb.	McGovern (BT)	McWilliams (L)	Clatterbuck (B)	Homan (ON)
120-lb.	Butera (OC)	Prucha (OS)	Van Sickle (ON)	McRoberts (B)
127-lb.	Barrett (OS)	Johnson (OC)	Butts (B)	Slemmons (GI)
133-lb.	Akins (BT)	Whitner (OC)	McWilliams (L)	Nemecek (OS)
138-lb.	Brown (OS)	Miloni (OC)	Tice (L)	McCullough (BT)
145-lb.	Stewart (ON)	Loos (LS)	Howard (OC)	Bammer (L)
154-lb.	Wilson (OT)	McWilliams (OC)	Olson (ON)	Fraley (L)
165-lb.	Crenshaw (OC)	Van Cleave (LS)	Fountain (OT)	Masek (OS)
175-lb.	Newville (OS)	Wallick (L)	Schulte (BT)	Meadows (OC)
Hvywt.	Raschke (ON)	Pickering (OS)	Weinfurter (BT)	Hoebet (NB)

New England

By **ROBERT S. SHEPHERD, SR., Lawrence Academy**

Thirty schools entered 135 wrestlers in the tenth annual New England Interscholastic Wrestling Association tournament at Needham High School, Needham, Mass. Kent School won the team trophy, a fourteen inch sterling Paul Revere bowl, awarded for the first time.

Needham took second place. Joseph Marciano of Mt. Pleasant won the "Cy" Carlson Trophy, awarded annually to the outstanding wrestler.

TEAM SCORING: Kent 38, Needham 37, Exeter 33, Mt. Pleasant 28, Mt. Hermon 28, Andover 24, Cranston 20, Belmont Hill 15, Milton 13, Governor Dummer 12, Roxbury Latin 12, Tabor 12, St. Mark's 10, Noble & Greenough 5, Warwick 5, Scituate 3, East Providence 3, Choate 3.

Class	Champion	Second	Third	Fourth
115-lb.	Pierce (N)	Turner (K)	Emmet (MH)	Partridge (M)
121-lb.	Noy (E)	Scarcella (N)	Souza (W)	Aidala (MP)
127-lb.	Bounomano (MP)	Johns (N)	Mercurio (C)	Lewis (T)
133-lb.	Fine (A)	Goodhue (M)	Wilson (E)	Lowden (MH)
138-lb.	Malof (RL)	Watkins (B)	Hamilton (K)	Gonnella (Cr)
147-lb.	Marciano (MP)	Baiter (K)	Gaynor (BH)	Turner (S)
157-lb.	Leary (GD)	VanFossen (E)	Eastman (N)	Smith (EP)
167-lb.	Carlsten (Cr)	Mann (A)	Angell (MH)	Herty (Ch)
177-lb.	Ferguson (K)	Cunniff (T)	Pinney (E)	Gulliver (MH)
Hvywt.	Sprenkle (MH)	Gaston (StM)	Grant (NG)	Rotan (A)

New Jersey

By **T. RALPH WILLIAMS, Roselle Park High School**

Union High School nosed out Bound Brook for the state team title in the 25th annual New Jersey State Interscholastic Athletic Association tournament at Somerville, N. J. The champs scored 14 points to Bound Brook's 13.

Bob Hogan, Millville's 15-pound champion, was voted the Donald M. Winger Award as the tournament's outstanding wrestler.

TEAM SCORING—Union 14, Bound Brook 13, Millville 9, North Plainfield 7, Overbrook Regional 7, Clark Regional 7, Paulsboro 6, Phillipsburg 6, Somerville 5, Teaneck 5, Roxbury 5, Rahway 4, Newton 3, Haddonfield 3, Vineland 3, Dover 3, Jefferson 3, Fair Lawn 2, Plainfield 1, Washington 1, Hunterdon Center 1, Hackettstown 1, Morris Hills 0.

Class	Champion	Second	Third	Fourth
106-lb.	Zelasny (B)	Balon (Ra)	DiOrio (F)	Trineer (Hac)
115-lb.	Hogan (M)	Tullo (B)	Jacknow (Ra)	Purdy (MH)
123-lb.	Rossi (Ro)	Makerow (M)	Schaaf (Had)	Osmun (Ph)
130-lb.	Balquist (T)	Maden (Pa)	MacGregor (Had)	Hassay (Ro)
136-lb.	Gentile (B)	Mazzoni (V)	Mirra (Had)	Creekmur (U)
141-lb.	Brauman (U)	Reposa (L)	Leta (NP)	Coyle (Pl)
148-lb.	Kinney (S)	Covington (O)	Sellitto (F)	Rickes (Ra)
157-lb.	Soto (U)	Grossi (N)	Guidi (W)	Maier (S)
168-lb.	Stem (Ph)	MacGrath (U)	Ferus (M)	Reid (S)
178-lb.	England (NP)	Ellison (O)	Ditomino (Pa)	Teyhen (HC)
Hvywt.	Sisia (C)	Sharer (D)	Gross (J)	Housell (B)

Central New York

By **BILL FARIEL**

The fifth annual Central New York Wrestling League tournament was held at Canastota Central with Holland Patent Central winning the title.

Auburn's Schuler, 154-pound champion, was awarded the Outstanding Wrestler trophy. The 15 competing schools entered 130 wrestlers in the tournament.

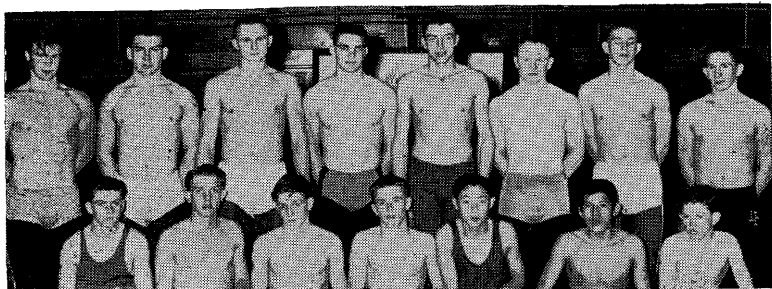

IDAHO SCHOOLBOY TITLISTS: Left to right, front row—Treasure (Marsh Valley), Smith (Bonneville), Packer (Snake River), Price (Blackfoot), Nakano (Marsing), Cereno (Blackfoot), Marshall (North Fremont); back row—Whelchel (Caldwell), Stone (Blackfoot), Ellis (Boise), Hill (Malad), Smith (Grace), Hagler (Caldwell), Miller (Boise), Evens (Idaho Falls).

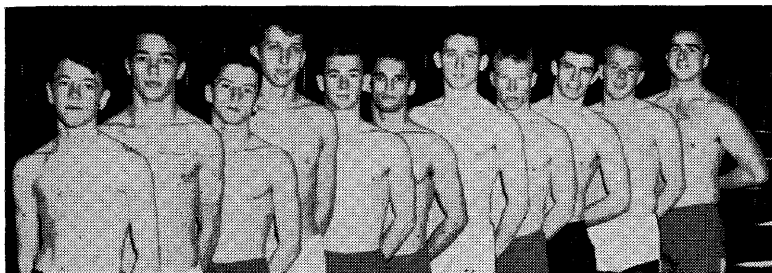

ALABAMA'S HIGH SCHOOL BEST: Left to right—Hamilton (Clift), Mann (Benjamin Russell), Yates (Clift), Price (Benjamin Russell), Golden (Clift), Johnson (Clift), Lee (Benjamin Russell), Dean (Clift), Baird (West End), Williams (Benjamin Russell), Cash (Clift).



INDIANAPOLIS BROADRIPPLE—CO-HOLDERS OF INDIANA CROWN: Left to right, front row—McKown, McNairy, R. Herald, J. Herald; middle row—Quick, Shipley, Binford, Oestrike; back row—Sirka, Dixon, Cox, Johnson, Sutton, Jessee (coach).

TEAM SCORING—Holland Patent 36, Auburn 31, Oneida 30, Rome 29, Frankfort-Schuyler 29, Richfield Springs 25, Canastota 22, West Genesee 13, Baldwinsville 12, Chittenango 11, Vernon-Verona-Sherrill 11, North Syracuse 10, Van Hornesville 8, Sauquoit 7, Jamesville-DeWitt 1.

Class	Champion	Runner-up	Class	Champion	Runner-up
95-lb...	LaComb (HP)	LaMonica (FS)	138-lb...	Charbonneau, FS	Woytowich (RS)
103-lb...	Cranfield (A)	Wheeler (NS)	145-lb...	Lucarelli (Ca)	Goodwin (R)
112-lb...	Perling (O)	Manore (FS)	154-lb...	Schulter (A)	White (HP)
120-lb...	James (O)	Dreizler (HP)	165-lb...	Crosby (A)	Sherman (HP)
127-lb...	Franco (R)	Hazen (Ca)	175-lb...	Raichlin (WG)	Eastwood (RS)
133-lb...	Oldick (RS)	DiBella (R)	Hvywt...	Greene (FS)	Wesseldine (Ch)

New York — Section III

By ED WEED

The annual Sectional Wrestling Tournament was held at Rome, with Watertown taking team honors for the second consecutive season.

Barnett, 154-pound champion from Watertown, was awarded the Outstanding Wrestler's trophy. The tournament attracted 226 entries from 26 competing schools.

TEAM SCORING—Watertown 58, Norwich 37, Rome 36, Iliion 33, Auburn 29, Oneida 29, Little Falls 24, Lowville 24, Carthage 19, Richfield Springs 19, Holland Patent 19, Chittenango 16, Canastota 15, Oneonta 15, Frankfort-Schuyler 15, Adams Center 11, Baldwinsville 11, Vernon-Verona-Sherrill 10, Mexico 10, Herkimer 9, Van Hornesville 9, North Syracuse 9, West Genesee 9, Sauquoit 6, Jamesville-DeWitt 4.

Class	Champion	Runner-up	Class	Champion	Runner-up
95-lb...	Jones (I)	Wheeler (NS)	138-lb...	Scheer (N)	Blondin (Car)
103-lb...	Cranfield (A)	Ingersoll (L)	145-lb...	Noll (I)	Lucarelli (Can)
112-lb...	Alteri (W)	Scheer (N)	154-lb...	Barnett (W)	Schulter (A)
120-lb...	James (Oneida)	Crabb (W)	165-lb...	Saiff (W)	Conti (Car)
127-lb...	Franco (R)	Jeffers (W)	175-lb...	Raichlin (WG)	LaClair (W)
133-lb...	Oldick (RS)	DiBella (R)	Hvywt...	Hetzmanek (LF)	Reed (AC)

New York — Section IV

By RICHARD H. BROWN, Chairman, Section IV

The twelfth annual Section IV wrestling finals were held at Ithaca High School and again Ithaca walked away with honors. It was crowned Class A and Section IV champion and also took five individual crowns. Greene Central School won the Class B title. Francis Leonard of Deposit was voted the outstanding wrestler.

Class	Champion	Runner-up
95-lb.	Leonard (Deposit)	Johns (Ithaca)
103-lb.	Bush (Windsor)	Franciamone (Ithaca)
112-lb.	Secord (Ithaca)	Wilcox (Windsor)
120-lb.	Meldrin (Cortland)	Kolbach (Windsor)
127-lb.	Leonard (Owego)	Heene (Vestal)
133-lb.	Briggs (Vestal)	Dreizler (Ithaca)
138-lb.	Orr (Greene)	Allen (Ithaca)
145-lb.	Capolongo (Ithaca)	Turner (Vestal)
154-lb.	Iacovelli (Ithaca)	Dwyer (Elmira Heights)
165-lb.	Cummings (Ithaca)	Shibley (Chenango Forks)
175-lb.	Michaels (Ithaca)	Lobdell (Greene)
Hvywt.	Ferro (Cortland)	Watkins (Windsor)



Valley),
Cerano
(Black-
Boise),



Benja-
Clift),
ussell),



left to
hipley,

North Carolina

By **STEVE GABRIEL**, *Coach, Appalachian High School*

Appalachian High School of Boone defended its state title by sending eight men into the finals with seven of them crowned as champions. The tournament was held at Burlington with 11 schools competing for the title with a total of 118 wrestlers in the tournament.

Appalachian's Bill Cook, 120-pound champion, was awarded the "Outstanding Wrestler" trophy. Boys who successfully defended their titles included Sammy Critcher and Tommy Owsley of Appalachian, Jerry Hollifield of Burlington and Dale Johnson of Greensboro. Appalachian High School has been undefeated in regular season matches for a period of six years.

TEAM SCORING—Appalachian 109, Goldsboro 69, Asheboro 63, Burlington 57, Greensboro 57, Myers Park 38, Southwest 28, Greenville 18, New Bern 14, High Point 12, Salisbury 4.

Class	Champion	Second	Third	Fourth
95-lb.	Moretz (Ap)	Patterson (Gr)	Askins (Go)	Carter (So)
103-lb.	Hales (Go)	King (Ap)	Bowden (Ash)	Hauser (So)
112-lb.	Critcher (Ap)	Arthur (Gr)	Ward (Go)	Jones (So)
120-lb.	Cook (Ap)	May (B)	Keck (Go)	Cornatzer (So)
127-lb.	Owsley (Ap)	Hayes (B)	Thomas (MP)	Lane (Go)
133-lb.	Vines (Ap)	Levy (Gr)	Newsome (B)	Millikan (As)
138-lb.	Brown (Ap)	Lassiter (B)	Edwards (MP)	Andrews (Gr)
145-lb.	Hollifield (B)	Bunting (As)	Williard (MP)	Fidler (Gr)
154-lb.	Coleman (Ap)	Leggett (As)	Ellison (Go)	Roberts (Gr)
165-lb.	Johnson (GR)	Allison (MP)	Kimball (B)	Williamson (So)
175-lb.	Dalton (As)	Davis (NB)	James (HP)	Richardson (So)
Hvywt.	Ellis (Go)	Hulin (As)	Evans (Gr)	Wilson (Ap)

North Dakota

By **HAROLD PEDERSEN**

Williston High School won the North Dakota tournament with six individual champions and a team score of 128 points.

Wrestling increased enormously last year and an official state meet will be held next year provided 16 teams enter the competition.

TEAM SCORING—Williston 128, St. Mary's 94, Assumption Abbey 71, Rugby 26, Columbus 23, Minot 20, Dickinson 18, Valley City College High 5.

Class	Champion	Runner-up	Class	Champion	Runner-up
95-lb.	Stewart (W)	Bonsness (C)	138-lb.	Mollman (SM)	Smith (MM)
103-lb.	Harp (W)	Britsch (R)	145-lb.	Nelson (W)	Lies (AA)
112-lb.	Schoch (SM)	Moody (W)	154-lb.	Lenhardt (SM)	Nelson (W)
120-lb.	Volk (R)	Digerness (W)	165-lb.	Webb (W)	Boespflug (D)
127-lb.	Gartner (SM)	Nelson (W)	175-lb.	Jackson (W)	Grosz (SM)
133-lb.	Webb (W)	Logosz (AA)	Hvywt.	Wehrman (AA)	Irgens (W)

Ohio

By **FRED SCHLEICHER, JR.**, *Coach, Ohio University*

Ohio High School wrestling is rapidly spreading and increasing over the entire state. Of the 53 schools represented in the tournament, from six district eliminations, 37 schools figured in the scoring. Euclid High School with unusual team balance, walked off with team honors by the widest margin in many years. Defending champion, Maple Heights, was second.

TEAM SCORING—Euclid 76, Maple Heights 50, John Marshall 40, Bedford 36, John Adams 32, Berea 29, Garfield Heights 24, Crestwood 17, Shaker Heights 16, Bridgeport 16, Toledo Whitmer 15, Cleveland South 15, Parma 13, Cleveland Heights 12, St. Joseph 10, Lakewood 9, North Canton 9, Toledo Central 8, Wooster 7, West Tech 6, Collinwood 6, Cuyahoga Falls 5, East Liverpool 5, Steubenville 5, Stow 4, Sylvania 4, Fremont 3, Kent State 3, Fostoria 3, Huron 3, Whitehall 3, Sandusky 2, Upper Arlington 2, Worthington 2, Linden McKinley 1, Mayfield 1, Clyde 1.

Class	Champion	Second	Third	Fourth
103-lb.	Linx (P)	Krean (MH)	Morris (NC)	Palmisano (GH)
112-lb.	DiSanto (JM)	Schaffer (Ber)	Schonauser (E)	Kotlan (WT)
120-lb.	Green (E)	Scavinsky (MH)	Pyros (L)	Vataha (GH)
127-lb.	Hehr (Br)	Klabik (Bed)	Kasler (JM)	Weissberg (CH)
133-lb.	Ross (E)	Morrill (JM)	Falzini (Bed)	Hoppel (EL)
138-lb.	Cook (Ber)	Codner (Bed)	Tobin (JM)	Weiss (SH)
145-lb.	Graddy (JA)	Murphy (E)	Heilinger (MH)	Reilly (TC)
154-lb.	Paz (E)	Brown (Cr)	Johnson (MH)	Miller (Bed)
165-lb.	Kilroy (JA)	Karl (GH)	Rohrict (E)	Ban (SH)
175-lb.	Arlsanian (CS)	Apling (TW)	Verba (Co)	Watson (E)
Hvywt.	Beechuk (MH)	Weed (StJ)	Wolter (CH)	Hugus (Ste).

Oklahoma

By JESS HOKE

Perry was host to the championship meet which was marked by good crowds and close competition in every division. Tulsa Rogers won the title.

Rogers was second in the regional meet and three individual regional winners lost out in the state tournament.

TEAM SCORING—Tulsa Rogers 40, Edmond 32, Perry 32, Sapulpa 28, Stillwater 28, Putnam City 22, Tulsa Central 22, Blackwell 20, Tulsa Edison 19, Ponca City 17, John Marshall 16, Midwest City 14, Geary 12, Bristow 6, Del City 4, Capitol Hill 1, Chillico 1, Norman 1, Classen 0, Harding 0, Northwest Classen 0, Tulsa Webster 0.

Class	Champion	Second	Third	Fourth
106-lb.	McCracken (St)	Ellis (TR)	Huffman (JM)	Griffin (E)
115-lb.	Willingham (Sa)	Peck (G)	Northcott (TC)	Dutsch (TE)
123-lb.	Wilson (PoC)	Walker (TC)	Lawson (RiC)	Chalk (Sa)
130-lb.	Whitfield (PuC)	James (TR)	LaMar (E)	Reding (G)
136-lb.	Favor (Sa)	Terry (E)	Keeley (Bl)	Mornhinweg (P)
141-lb.	Eckles (TR)	Groom (P)	Ralston (Br)	Reid (Bl)
148-lb.	Eaves (TE)	Millican (MC)	Bradshaw (P)	Curns (PoC)
157-lb.	Gregg (P)	Eades (St)	Canterbury (PuC)	Washburn (MC)
168-lb.	Haws (E)	Mahan (TR)	Frick (TC)	Johnson (DC)
Hvywt.	Brisco (Bl)	Lively (JM)	Ellis Banning (St)	Webb (TE)

Oregon

By JOHN H. EGGERS, Sports Publicity Director, Oregon State College

Sweet Home edged past Redmond and Newberg, the defending titlist, to sweep the 11th annual state high school championship staged at Oregon State College.

The Huskies placed only one individual champion, but scored heavily with a well-balanced team. The 1958 tournament was the most successful ever in this state, both in terms of attendance and in interesting matches.

TEAM SCORING—Sweet Home 51, Redmond 47, Newberg 46, Klamath Falls 36, Franklin 30, Milwaukie 28, Grants Pass 18, Hillsboro 18, Canby 17, Gresham 17, Tillamook 17, Sutherlin 17, David Douglas 15, Marshfield 15, Lebanon 15, Bend 14, West Linn 12, Springfield 11, Dallas 11, Illinois Valley 11, Park Rose 10, Roseburg 10, Scappoose 10, Woodrow Wilson 10, North Marion 8, Oregon City 7, Prineville 7, Tigard 7, Burns 6, Estacada 6, Benson 5, Bend 5, Cascade 4, Jefferson 4, South Eugene 4, Molalla 3, Sandy 3, Albany 2, Lincoln 2, Central 1, Crater 1, Medford 1, North Salem 1, South Salem 1, Reynolds 1, Roosevelt 1.

<i>Class</i>	<i>Champion</i>	<i>Second</i>	<i>Third</i>	<i>Fourth</i>
98-lb.	Payne (SH)	Holmes (G)	Dustin (Tig)	Weaver (Bu)
106-lb.	McFarland (KF)	Marmelejo (IV)	Keller (SH)	McFarland (Sc)
115-lb.	Perez (Su)	Bender (KF)	Allison (G)	Andrews (SH)
123-lb.	Stanton (Red)	Payne (SH)	Dexter (PR)	Roberts (KF)
130-lb.	Markee (Til)	Conway (N)	Malick (Le)	Loomis (DD)
136-lb.	Seal (Red)	Wallace (WL)	Morton (OC)	Byrd (GP)
141-lb.	Finley (N)	Bishop (SH)	Davidson (Red)	Wilson (Sc)
148-lb.	Brewster (Mi)	Douglas (N)	Wood (Ma)	Day (KF)
157-lb.	Schneider (Can)	Dean (Red)	Winterbottom (GP)	Rambo (E)
168-lb.	Medley (H)	Fenton (Mi)	Coleman (P)	Bryant (SE)
178-lb.	Ferkis (Bend)	Holmes (DD)	Coleman (NM)	Jenkins (Ma)
194-lb.	Clock (N)	Austin (D)	Stout (Sp)	Held (WL)
Hvywt.	Gallaher (F)	Morison (F)	Simons (Ros)	Miller (Le)

Pennsylvania

By MARK N. FUNK

Interscholastic wrestling continues to increase in Pennsylvania. This year over 200 high schools participated in interscholastic wrestling. Eleven of our twelve districts select district champions. A number of districts find it necessary to hold as many as four qualifying tournaments for the final district tournament. Well over 7000 attended the four regional tournaments and almost 8000 attended the final tournament held in two sessions at the Pennsylvania State University.

<i>Class</i>	<i>Champion</i>	<i>Runner-up</i>
95-lb.	Jodhnson (Lock Haven)	Purdy (Easton)
103-lb.	Hopkins (Trinity)	Martzall (Manheim Central)
112-lb.	Stauffer (Kingston)	Maughn (Canonsburg)
120-lb.	Tressler (State College)	Gorant (Shamokin)
127-lb.	Mosser (Bethlehem)	Hershey (Manheim Central)
133-lb.	Harris (Philipsburg)	Kalokerinos (Latrobe)
138-lb.	Byard (Waynesburg)	Shearer (Manheim Central)
145-lb.	Edmunds (Forty Fort)	Fake (Mechanicsburg)
154-lb.	Pifer (Bellefonte)	Allen (Muncy)
165-lb.	Rushatz (Allentown)	Dixon (Philipsburg)
185-lb.	Bazzoli (Chartiers-Houston)	Kemble (Hershey)

Rhode Island

By RALPH G. ANDERTON, *Coach, Brown University*

Sparked by four individual titlists, Mount Pleasant won the Rhode Island state tournament, outscoring Cranston by ten points before 3,500 spectators.

Vincent Buonomano of the championship team was voted the outstanding wrestler of the tourney.

TEAM SCORING—Mount Pleasant 80, Cranston 70, Warwick 35, La Salle 31, Moses Brown 23, Central 19, East Providence 16, Providence Country Day 9, Hope 8.

<i>Class</i>	<i>Champion</i>	<i>Second</i>	<i>Third</i>
115-lb.	Keach (LS)	Dimillio (MP)	Nelson (PCD)
121-lb.	Sousa (W)	Aidala (MP)	Palumbo (CR)
127-lb.	Buonomano (MP)	Mercurio (CR)	Fain (LS)
133-lb.	Dicenzo (MP)	Phillips (W)	Curry (CR)
138-lb.	Gonella (CR)	Angel (W)	Chirico (CE)
147-lb.	Marciano (MP)	LeBlanc (CR)	Kearney (LS)
157-lb.	Smith (EP)	Rooks (MP)	Magarian (CE)
167-lb.	Carlsten (CR)	Lemoi (CE)	Waldruff (H)
177-lb.	D'Amico (MP)	Dalen (LS)	Howland (PCD)
Hvywt.	Bertch (CR)	Cianci (MB)	Volpe (MP)



CLASS MONARCHS IN PENNSYLVANIA: Left to right, front row—Johnson (Lock Haven), Hopkins (Trinity), Stauffer (Kingston), Tressler (State College), Mosser (Bethlehem); back row—Harris (Philipsburg), Byard (Waynesburg), Edmunds (Forty Fort), Pifer (Bellefonte), Rushatz (Allentown), Bazzoli (Chartiers-Houston).

South Dakota

By AL EVANS, Redfield High School

The first South Dakota State wrestling tournament, held at Redfield, S. D., was won by Spearfish which captured six individual titles.

About 350 people watched the champs edge runner-up Redfield by six points as some 50 wrestlers took part in the competition.

Wendell Summer of the South Dakota School for the Blind was named the tourney's outstanding wrestler.

TEAM SCORING—Spearfish 105, Redfield 99, Miller 35, South Dakota School for the Blind 31, Britton 6, St. Lawrence 6.

Class	Champion	Second	Third	Fourth
95-lb.	Mowry (R)	Wallman (M)	Asusman (S)	_____
103-lb.	Leesch (R)	Linander (S)	Rudd (M)	_____
112-lb.	Summer (SDB)	Hoch (R)	St. Sauver (B)	King (S)
120-lb.	Robinson (S)	Fraser (M)	Wimer (R)	_____
127-lb.	Johnson (S)	Dean (M)	Morton (R)	_____
133-lb.	Trenhaile (R)	Hayes (unatt)	Lauritsen (SDB)	Grogan (M)
138-lb.	Buchholz (S)	Fraser (SDB)	D. Morey (R)	_____
145-lb.	Christofferson (S)	G. Morey (R)	Wallman (M)	Grindstone (SDB)
154-lb.	Neu (R)	Christofferson (S)	Newman (unatt)	Evans (M)
165-lb.	Christofferson (S)	Sjodin (R)	Sessione (SL)	Snodgrass (unatt)
Hvywt.	Butterfield (S)	Roelman (R)	Fanning (SL)	Bomebright (unatt)

Utah

By HORACE H. ROSE

TEAMS IN SCORING ORDER—"A" Schools at Ben Lomond: Davis, Weber, Granite, Olympus, Bear River, Cyprus, Ogen, East, West, Bingham, Box Elder, Bountiful, Orem, South Cache, Jordan, Provo, Payson, Ben Lomond, Murray, Carbon, South, Spanish Fork. "B" Schools at Wasatch: Uintah, Cedar, Millard, Pleasant Grove, South Summit, Monticello, Delta, Grand, San Juan, Wasatch, American Fork, Brigham Young, Union, Lehi.

<i>Class & Meet</i>	<i>Champion</i>	<i>Second</i>	<i>Third</i>	<i>Fourth</i>
95-lb. A	Asay (Gte)	Markos (Web)	Irvine (E)	Montoya (Mur)
95-lb. B	Neff (SJ)	Harding (Mid)	Bottomfield (PG)	Billings (Uin)
103-lb. A	Pilkington (Web)	Hagen (Cyp)	Smout (Gte)	Evans (Bou)
103-lb. B	Smith (Ced)	Whattcott (Mid)	Boren (Uin)	Pearson (Mon)
112-lb. A	Carter (BE)	Royball (Dav)	Martinez (Bin)	Cook (Jor)
112-lb. B	Urie (Ced)	Turner (Mon)	Smith (PG)	Watson (Was)
120-lb. A	Gonzales (Web)	Manazaneras (Dv)	Webb (Gte)	Rackich (Bin)
120-lb. B	Manning (Ced)	Smuin (Uin)	Kockerhams (PG)	Carlson (Was)
127-lb. A	Smith (BR)	Fielding (Web)	Cutler (Gte)	Endo (Jor)
127-lb. B	Callister (Del)	Prows (Mid)	Randall (Grd)	Hullinger (Uin)
133-lb. A	Thalman (SC)	Shelton (BR)	Jensen (Oly)	Mitchell (Dav)
133-lb. B	Southam (Uin)	Maxfield (Del)	Richins (PG)	Baum (Leh)
138-lb. A	Coolley (Dav)	Jeppson (E)	Huggins (BE)	Parry (Web)
138-lb. B	Page (SS)	Pelliccia (Mon)	Robinson (Mld)	Goetz (AF)
145-lb. A	Huber (Wes)	Saltus (Bin)	Wheelwright (Ogd)	Anderson (BR)
145-lb. B	Nixon (Mld)	McKee (Uni)	Inouye (AF)	Christensen (PG)
154-lb. A	Foxley (Dav)	McDonald (Oly)	Neilson (Pay)	Norris (Cyp)
154-lb. B	Murray (Uin)	Hone (Mld)	Anderson (Ced)	Peterson (Leh)
165-lb. A	Thorn (Ogd)	Smith (Wes)	Liddard (Pro)	Albertson (Cyp)
165-lb. B	Bushell (SS)	Dull (Grd)	McKnight (Ced)	Nielson (Was)
175-lb. A	Dangerfield (Oly)	Prisbrey (Bou)	Lund (Cyp)	Holliday (BL)
175-lb. B	Lewis (Uin)	Kormas (BY)	Prince (Ced)	Finlinson (Mld)
Hvywt. A	Prestwick (Ore)	Akins (Ogd)	Ketchum (Cyp)	Green (Gte)
Hvywt. B	Ash (PG)	Rider (Ced)	Baxendale (Uin)	Carson (AF)

Virginia

By BILL MARTIN, *Granby High*

Granby High School of Norfolk won the Virginia State championship copping six individual titles. Coaches agreed that the competition was the best in the ten-year history of the meet. Mr. Montague, meet director, received a trophy for his efforts in promoting the event.

TEAM SCORING: Granby 110, Warwich 60, Washington-Lee 47, Norview 39, Princess Anne 36, Wilson 35, George Washington 34, Blacksburg 28, William Fleming 23, Virginia School for Deaf and Blind 22, Jefferson Senior 19, Oscar Smith 13, Maury 10, Great Bridge 9, Wakefield 6, Douglas Freeman 5, Hermitage 5, Cradock 4, Climax 2, John Marshall 0, Thomas Dale 0.

<i>Class</i>	<i>Champion</i>	<i>Second</i>	<i>Third</i>	<i>Fourth</i>
95-lb.	Seymour (WL)	Powell (G)	Harris (PA)	Clough (DF)
103-lb.	Simons (G)	Dougherty (N)	Evans (WL)	Boyd (PA)
112-lb.	Johnson (G)	Chappell (W)	Venturino (B)	Liles (GW)
120-lb.	D. Harris (PA)	Davidson (JS)	Olah (GB)	Merriam (G)
127-lb.	Knowles (G)	Little (War)	Mallander (WL)	Smith (B)
133-lb.	Guttermuth (G)	Bevins (B)	McCune (WL)	Osborne (WF)
138-lb.	Langston (G)	Abel (VB)	Robinson (N)	Shorter (War)
145-lb.	Bower (War)	Everette (GW)	Belvins (WL)	Bamforth (Pa)
154-lb.	Harrison (G)	Cox (VB)	Stinnette (WF)	Ledyon (Wi)
175-lb.	Bartlett (Wi)	Bowling (WF)	Bradley (GW)	Gautreaux (M)
175-lb.	Rust (N)	Fooks (War)	Thomas (PA)	Sher (Wak)
Hvywt.	Beard (OS)	Jordan (War)	Bradley (GW)	Goodsell (WL)

Washington

By BILL TOMARAS, *Wrestling Coach, Washington State College*

Coach Bo Campbell's Burlington-Edison high school wrestling team won its first state championship, totalling 55 points to best Moses Lake in a thrilling state tournament held at Washington State College.

Several teams demonstrated good scoring power in tournament competition but Burlington-Edison pulled away from its competitors by placing in six weight classes.

Dennis Warren, 115-pound champ from Othello and Glen Humphrey, 165-pound winner from Moses Lake, were voted as outstanding wrestlers of the tournament.

TEAM SCORING—Burlington-Edison 55, Moses Lake 45, Mt. Vernon 41, Ft. Vancouver 33, Everett 26, Ephrata 24, Kelso 24, Pullman 22, Hudson's Bay 18, Anacortes 16, Walla Walla 16, Sedro Woolley 15, Lincoln 14, Lake Washington 13, Othello 13, Richland 12, Centralia 11, Longview 9, Quincy 9, Bethel 6, Cheney 6, Pasco 6, Battle-ground 3, Mead 2, Wenatchee 2, Kennewick 1.

<i>Class</i>	<i>Champion</i>	<i>Second</i>	<i>Third</i>	<i>Fourth</i>
106-lb.	Kerr (MV)	Tipton (K)	Zacek (B)	Vigil (Q)
115-lb.	Warren (O)	Wahl (Pu)	Walden (BE)	Taylor (FV)
123-lb.	Cabe (SW)	Crawford (ML)	Dougal (HB)	Berry (Pu)
130-lb.	Bryce Cook (BE)	Wolfe (ML)	LaCroix (HB)	Smith (K)
136-lb.	Bruce Cook (BE)	Harris (Lo)	Gillingham (Ch)	T. Pierce (LW)
141-lb.	Sperber (Ev)	Rackner (MV)	Lybbert (ML)	Iverson (LW)
148-lb.	Reynolds (Ep)	Kingma (MV)	Shinn (BE)	Hayes (FV)
157-lb.	Cabe (Ev)	West (BE)	Bell (FV)	Moesch (LW)
168-lb.	Humphrey (ML)	Stierwalt (Ep)	Showers (WW)	Boggs (HB)
178-lb.	Kuykendall (R)	Spray (WW)	Schols (BE)	Meecham (K)
194-lb.	Way (A)	Clevidence (FV)	Garrett (MV)	Babbitt (Pu)
Hvywt.	Pruett (Li)	Worrel (Ce)	Friauf (FV)	Williams (Pa)

West Virginia

By JACK L. MILLER

The 13th annual state tournament saw Parkersburg High School, coached by Robert Dutton, win its second consecutive title and its third in four years.

Terry Dunscomb of Fairmont West won his third straight crown.

TEAM SCORING—Parkersburg 83, Fairmont West 41, Beckley 29, Barboursville 19, Sophia 12, University High 11, Hinton 9, Morgantown 9, Shady Springs 8, Kingwood 5, Richwood 5, Wayne 4, Webster Springs 2, Weirton 1.

<i>Class</i>	<i>Champion</i>	<i>Second</i>	<i>Third</i>	<i>Fourth</i>
106-lb.	Mattern (P)	Plumley (H)	Buchanan (M)	Clay (BA)
115-lb.	Atkinson (P)	Wright (F)	Thompson (BE)	Bowdell (WS)
123-lb.	Wines (P)	Wellman (BA)	Spinelli (BE)	Osborne (BA)
130-lb.	Rhodes (P)	Meade (BE)	Wills (BE)	Travaglino (W)
136-lb.	Mills (S)	Farley (BA)	Cochran (P)	Burnett (F)
141-lb.	Zeck (F)	Beafore (F)	Mosley (F)	McConkey (BA)
141-lb.	Auville (P)	Lester (SS)	Strahin (K)	Harris (WS)
157-lb.	Dunscomb (F)	Marquis (P)	Adams (R)	White (BA)
168-lb.	Zaleski (U)	Holbert (P)	Bradshaw (W)	Meadows (H)
Hvywt.	Nedeff (P)	James (BE)	Edwards (M)	Jefferson (BA)

Wisconsin

By GEORGE MARTIN

TEAM SCORING—Milwaukee South 19, Valders 17, Kenosha 16, Marshfield 15, Coleman 11, Luxemburg 10, Madison East 10, Stevens Point 10, Wisconsin High 9, Stoughton 6, Madison West 5, Manitowoc 5, Sevastopol 5, Janesville 4, Tomah 4, Bonduel 3, Milwaukee Rufas King 3, Schofield 3, Milwaukee Bay View 2, Milwaukee Boys Tech 2, Milwaukee North 2, Muskego 2, Racine Park 2, Amery 1, Menomonie 1, Milwaukee Riverside 1, Waupun 1, West Allis Central 1.

<i>Class</i>	<i>Champion</i>	<i>Second</i>	<i>Third</i>	<i>Fourth</i>
103-lb.	Spilde (ME)	Bohachek (Man)	McPherson (K)	O'Grady (Mu)
112-lb.	Rank (L)	Ouale (St)	Barr (K)	Stiehm (Sc)
120-lb.	Hamel (WH)	Martin (MW)	Miller (J)	Wesenberg (MRK)
128-lb.	Kansos (MS)	Weiss (K)	Nischke (B)	Hosni (WAC)
136-lb.	Holtbets (Mar)	Peterson (C)	Osvetic (MBT)	Elvekrog (St)
145-lb.	Sickingner (V)	Pagel (SP)	Johnson (MS)	Warwick (A)
155-lb.	Nehrkorn (MS)	Gilson (Tomah)	Jossart (L)	Pelky (RP)
165-lb.	Alderman (SP)	Krzykowski (MS)	Nesbit (ME)	Fenendael (L)
180-lb.	Larson (Mar)	Shephenson (Se)	Davis (ME)	Moton (MN)
Hvywt.	Teesch (V)	Pillath (C)	Mohr (K)	Kubinski (MBV)

Wyoming

By **DALE FEDERER, Coach, Saratoga High School**

The Wyoming State High School Tournament was won by Laramie High School. Closely following Laramie in the scoring were Newcastle with 54 points, Cheyenne with 53 and defending champion Saratoga with 50.

Outstanding wrestler was Gerald Carabeau of Powell, high point man was Dave Edington of Saratoga and the fastest pin trophy was won by Kermit Rollins of Rock Springs. Saratoga copped the Class "B" trophy.

TEAMS—Casper, Cheyenne, Cody, Evanston, Greybull, Lander, Laramie, Lovell, Newcastle, Powell, Riverton, Rock Springs, Saratoga, Thermopolis, Worland, Wheatland.

Class	Champion	Second	Third	Fourth
95-lb.	Rollins (RS)	Fujikawa (Wo)	Bush (Ca)	Bates (N)
103-lb.	Hewitt (Ch)	Farlow (Co)	Rote (Lar)	Mercado (Wo)
112-lb.	Bickel (R)	Dearinger (Lar)	Cobos (Lo)	Oxford (S)
120-lb.	Argento (P)	Wilson (Co)	Hammond (T)	Wedemeyer (Wh)
127-lb.	Edington (S)	Nelson (T)	Chavez (R)	Barnett (Co)
133-lb.	Maki (S)	Young (Lar)	Burrows (Wo)	Norton (Lan)
138-lb.	Sweets (RS)	Gaskill (N)	Shaner (T)	Walton (E)
145-lb.	Eads (Lar)	Samuelson (Ca)	Michelsons (Lo)	Biorgialli (N)
154-lb.	Burnette (N)	Smith (Ch)	Bond (RS)	Reed (Lan)
165-lb.	Perue (S)	Spicka (Ch)	Colling (Lar)	Witter (Co)
Hvywt.	Caraveau (P)	Williams (N)	Larabee (Ch)	Isabel (G)

Academy School Tournament

By **FREDERICK R. KUHN, Coach, Mercersburg Academy**

The Hill School, with six individual champions, rolled up 126 points to capture the 23rd Prep School title. Kirk Pendleton of the Academy of the New Church was the coaches' choice as the outstanding wrestler in the tournament.

TEAM SCORING—Hill 126, Milton Hershey 59, New Church 43, New York Military 33, Shady Side 31, Mercersburg 29, Kiski 26, St. Paul's (NY) 24, McDonogh 16, Poly Prep 12, Wyoming Seminary 11, Fishburne Military 10, Peekskill Military 8, Eastern Military 7, Albany Academy 6, Riverdale Country 5, St. Alban's 1.

Class	Champion	Second	Third	Fourth
106-lb.	Lieberman (SS)	Londono (NYM)	Kellner (H)	Galef (R)
115-lb.	Chappell (H)	Menser (MH)	Wright (M)	North (NC)
123-lb.	Dyer (H)	Stroh (NYM)	Sekorske (EM)	Doberstein (MH)
130-lb.	Mersereau (H)	Menser (MH)	Shelton (F)	Pitcairn (SS)
136-lb.	Malmstrom (SP)	Souders (MH)	Ellis (H)	Vastine (Me)
141-lb.	Moore (H)	Slingluff (Mc)	Klinger (MH)	Burnaforad (WS)
148-lb.	Pendleton (NC)	Mattern (Mc)	Rugh (H)	Pereira (P)
157-lb.	Detrixhe (H)	Klippenstein (NC)	Johnson (MH)	Franco (PP)
168-lb.	Rector (K)	Cochran (H)	Mergen (NC)	Halperin (NYM)
Hvywt.	Fox (H)	Sayers (SS)	Morgan (K)	Ebert (NC)

6th Annual Metropolitan Tournament

By **VICTOR BLUE, JR., Coach, Wakefield High School**

Washington-Lee High School of Arlington, Va., won the Metropolitan tourney with 110 points to Northwestern's 93.

The runner-up's Gary McClellan was voted the outstanding wrestler.

TEAM SCORING—Washington-Lee 110, Northwestern 93, Episcopal 50, Annapolis 39, Suitland 34, Wakefield 33, Woodberry Forest 23, St. Alban's 17, Gallaudet Prep 12, South Hagerstown 2, Southern 2, Montgomery Blair 0.

Class	Champion	Second	Third	Fourth
95-lb.	Seymore (WL)	Turrell (N)	Mikedes (W)	Hagan (E)
103-lb.	Evans (WL)	Lady (W)	Smith (A)	Hamilton (N)
112-lb.	McKerahan (WL)	Burton (N)	Bennett (SA)	Ripley (WF)

120-lb.	McClellan (N)	Winfield (E)	Cook (WL)	Rice (WF)
127-lb.	Maulander (WL)	Willard (A)	Morris (Su)	Bond (E)
133-lb.	Housler (N)	McCune (WL)	Nollan (Su)	Moser (SA)
138-lb.	Price (N)	Demboski (WL)	Jewell (A)	Thomas (W)
145-lb.	Lewnes (A)	Blevins (WL)	Shuford (E)	Willett (N)
154-lb.	Robertson (N)	Easterwood (WL)	Babcock (WF)	Smather (SA)
165-lb.	O'Meara (WL)	Berlowitz (G)	Goodwin (E)	O'Neal (N)
175-lb.	Mitchell (Su)	Sher (W)	DeButts (E)	Phillips (WF)
Hvywt.	Hillard (E)	Berkely (N)	Goodsell (WL)	Whittaker (W)

Mid-South Tournament

By DAVID SPENCER

McCallie School of Chattanooga won the Mid-South Association title by the biggest margin ever seen in the tournament. For coach Dave Spencer it was his third title in four years as head coach. The Blue Tornado finished with five individual champions and four runners-up after sending all twelve men into the semifinals.

Curtis Shelton of Castle Heights was named best wrestler.

TEAM SCORING: McCallie 117, St. Andrews 77, Castle Heights 39, Tennessee Military 35, Baylor 34, Columbia Military 28, Sewanee Military 21, Georgia Military 18.

Class	Champion	Second	Third	Fourth
100-lb.	Harlow (SA)	Armstrong (M)	Rogers (CH)	Parker (SM)
108-lb.	Spangler (M)	Bright (SA)	Henley (CH)	Owen (SM)
115-lb.	Smartt (M)	Miller (SA)	Hutson (TM)	Rawls (B)
123-lb.	Shelton (CH)	Lance (SA)	Sellers (M)	Stacks (TM)
130-lb.	Oldham (M)	Hale (SA)	Jennings (GM)	Sadler (TM)
137-lb.	Boehm (B)	George (GM)	Hale (SA)	Walker (M)
147-lb.	Russo (CH)	Corpening (M)	Auston (CM)	Coller (TM)
157-lb.	Brown (M)	Guarisco (CH)	Brice (SA)	Irvine (B)
167-lb.	Wiggins (SA)	Wunderlich (M)	Beck (CH)	Rockett (TM)
177-lb.	Yates (SM)	McCutchen (M)	Schwambach (CM)	Vaughan (CH)
191-lb.	Davis (M)	Vann (TM)	Tidwell (CM)	Mann (B)
Hvywt.	Guthrie (B)	Smith (CH)	Smith (CM)	Osteen (M)

North Central Association of Schools for Blind

By SY HALICZER

The Missouri School for the Blind swept team honors for the second time when coach Al Eberhardt's wrestlers amassed 129 points. Illinois, in only its third season, tied Iowa for second place in the annual conference meet.

A total of 94 entries from ten state schools participated in the meet. The quality of wrestling skill demonstrated was excellent as the visually handicapped are showing increased interest in wrestling.

TEAM SCORING—Missouri School for the Blind 129, Illinois Braille and Sight Saving School 46, Iowa Braille and Sight Saving School 46, Michigan School for the Blind 42, Kansas School for the Blind 36, Nebraska School for the Blind 35, Minnesota Braille and Sight Saving School 24, Kentucky School for the Blind 11, South Dakota School for the Blind 11, Wisconsin School for the Visually Handicapped 11.

Class	Champion	Second	Third	Fourth
95-lb.	Hart (Ia)	Dasher (Neb)	Parker (Mic)	Randall (Ka)
103-lb.	Oster (Mo)	Weems (Ill)	Carnes (Ky)	Rustvold (Ia)
112-lb.	Myers (Ill)	Sumner (SD)	Piel (Mo)	Allen (Ky)
120-lb.	Lauer (Mo)	Duran (Ka)	Pearson (Ia)	Filter (Mic)
127-lb.	Ney (Mo)	Machtrieb (Mic)	VandeHaar (Ia)	Hennes (Ka)
133-lb.	Sykes (Mo)	Barton (Ill)	Peterson (Min)	Ulrich (Mic)
138-lb.	Duciaome (Mo)	Fields (Wis)	Ruttan (Mich)	Schmidt (Ill)
145-lb.	Dinwiddie (Mo)	Faimon (Neb)	Blumenthal (Min)	Kapler (Ia)
154-lb.	Adams (Mo)	Crabbs (Ka)	Anteau (Mic)	Hynnek (Min)
165-lb.	Brown (Mo)	Jones (Ia)	Elena (Mic)	Bonesteel (Neb)
Hvywt.	Hoebet (Neb)	Johnson (Mo)	Chappell (Ill)	Mady (Ka)



MacGregor "The Choice Of Those Who Play The Game"

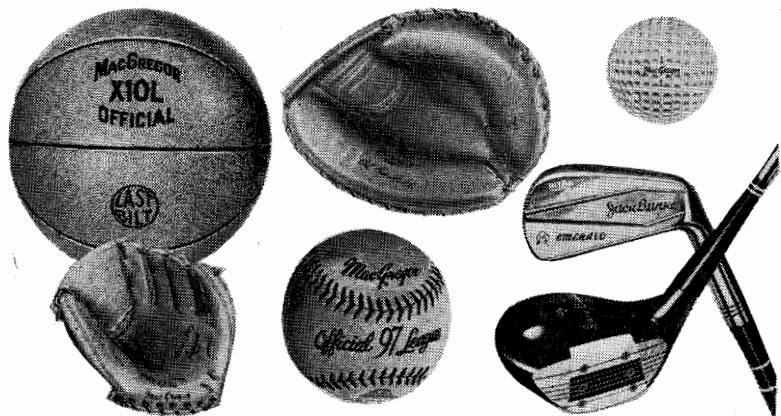

The best teams call for the best equipment — MacGregor!

For quick action on your sports equipment needs see your MacGregor dealer

The MacGregor Co., Cincinnati 32, Ohio • BASEBALL • FOOTBALL
BASKETBALL • SOFTBALL • GOLF • TENNIS • BADMINTON • SOCCER • TRACK

OFFICIAL WRESTLING GUIDE

OFFICIAL

Intercollegiate and Interscholastic

WRESTLING

RULES

B. R. PATTERSON, EDITOR

Major Rules Changes

Rule 3, Sec. 2a. When trunks are worn without tights, shirts shall be required.

Rule 5, Sec. 1a. For the first day of the National Collegiate Wrestling Championships the contestants will weigh in a maximum of six hours and a minimum of five hours before the meet is scheduled to begin.

Rule 7, Sec. 1. When the wrestlers are in the neutral position the match is started or resumed with the contestants standing opposite each other and on the 10-ft. circle. (Also Rule 8, Sec. 6.)

Rule 7, Sec. 4. When there is a decision by the referee and two judges at the end of the overtime the vote of this jury shall be recorded on the score sheet.

Warning penalties recorded in the main match shall be taken into consideration in determining the winner in the overtime.

Rule 8, Sec. 1b. Statement clarifies the position of the hand on the elbow in the referee's position on the mat. The *palm* of the hand shall be placed loosely on the *back* of opponent's elbow.

Rule 8, Sec. 7. Words changed to clarify that stalemate can be called when there is a pinning combination but should not be called when there is a pinning situation (fall imminent).

Rule 8, Sec. 12. Two point near fall is deleted. Three point near fall now includes one shoulder touching mat and other within one inch or less of mat for two full seconds.

Rule 8, Sec. 13a. Distance of shoulders to mat for a predicament is changed from four inches to three inches.

Rule 8, Sec. 15. Sentence added which states "In order to receive a forfeit, a wrestler must be dressed and appear on the mat."

Rule 9, Sec. 2. "Two points for near fall" is deleted from scoring system and summary of scoring.

Rule 10. A picture is added to illustrate the "Illegal Twisting Knee Lock."

Rule 10, Sec. 7i. Grasping clothing, mat or mat cover to prevent a *fall* is included as a violation. The penalty added for grasping clothing, mat or mat cover in defensive position is one point, no change for first and each subsequent penalty. (See Penalty Chart.)

Penalty Chart. Abusive and/or Unsportsmanlike Conduct—deduct one team point has been added as second penalty, removal from premises is now the third penalty for this infraction.

Greasy Substances on Skin and/or Objectional Pads and Braces—penalty statement now specifies that removal must be in allotted time of 3 minutes which is cumulative with injury time outs.

Stalling—statement changed to read “only one *first penalty* regardless of position.” Formerly was one *warning* regardless of position. First Penalty for stalling in the Neutral Position has been changed to “*1 point no change*” instead of “warning.”

Rule 11, Sec. 3b. Instead of one *warning* for stalling regardless of position the term First Penalty is used.

Rule 13, Sec. 3. A seating arrangement is provided for the officials when a multiple timer is used.

Rule 13, Sec. 17. Either hand may be raised in declaring the winner or a draw.

Rule 14, Sec. 3. The home management shall notify the visiting team at least 10 days prior to the meet if shirts will be required.

Rule 15, Sec. 1. Referee's attire is designated for the National Collegiate Wrestling Championships.

Rule 15, Sec. 2. Sentence concerning use of whistle indicates that whistle should be held ready for immediate use at all times. The words “in the mouth” have been deleted.

High School Modifications—5. The figure four head scissors has been restored as a legal hold. The double wristlock and all head locks remain as illegal holds in addition to those listed in Rule 10.

Illustrations and explanations have been added to clarify the double wrist lock, head lock and guillotine situations.

Index. A number of items have been added to the index.



NCAA WRESTLING RULES COMMITTEE: Left to right, front row—Ray Sparks (Springfield) Chairman, Everett Lantz (Wyoming), William Hammer (Oregon), F. G. Knorr (Kansas State); back row—Frank Walp (National H.S. Federation), Claude Reeck (Purdue), Charles W. Parker (Davidson), Dick Voliva (Rutgers).

Official NCAA Wrestling Rules

RULE I—ELIGIBILITY

SECTION 1. Each contestant must be an Amateur as defined in the rules of the National Collegiate Athletic Association and be eligible according to the rules and regulations of the college or university which he represents. Participants in the National Collegiate Wrestling Championships must represent institutions which are active members of the NCAA in good standing and must conform to the rules of eligibility adopted by the NCAA to apply to all annual championship meets conducted by this Association.

Note—See Rule 5, Section 4.

SECTION 2. All colleges, universities and institutions of learning in the United States with acceptable scholastic and athletic standards may be elected to membership in the NCAA. To comply with "acceptable scholastic standards" the institution must be on the approved list of the accepted accrediting agency of the district in which the institution is located.

SECTION 3. An institution is considered as having "satisfactory athletic standards" on approval of its standards by a two-thirds majority of the active members of the NCAA in the Association District in which the institution is located. Further information regarding application for membership may be obtained from the Executive Director of the NCAA, Walter Byers, 209 Fairfax Building, Kansas City 5, Mo. At least thirty (30) days should be allowed for the above procedure.

RULE II—REPRESENTATION

SECTION 1. An institution shall be represented by only one contestant in each weight class.

SECTION 2. No contestant shall be allowed to represent his institution in more than one class in each meet.

SECTION 3. A representative may not accept a forfeit in one weight class and compete in another class.

SECTION 4. A contestant who weighs-in for one weight class may be shifted to a higher weight class.

National Collegiate Championships SECTION 5. All entries to the National Collegiate Wrestling Championships which are received after the deadline date shall be charged a double entry fee. The deadline shall be nine days in advance of the first tournament session. When the team registers at the National Championships the institutional representative shall indicate the entry in each weight class in so far as it is possible before the weighing-in.

RULE III—MATS, COSTUMES AND EQUIPMENT

Mats SECTION 1. The wrestling area of the mat shall not be less than a square 24 feet by 24 feet. There shall be a mat area at least 5

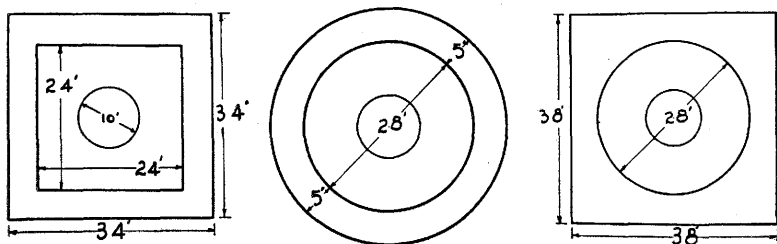

MINIMUM MAT SIZES

A circle with a diameter of 28 feet is a legal wrestling area providing there is a mat area at least 5 feet in width which extends around it.

feet in width which extends entirely around the wrestling area. The entire mat area shall be the same thickness which shall not be more than 4 inches nor less than the thickness of a mat which has the shock absorbing qualities of a 2-inch thick hair felt mat.

It is recommended that a moleskin, canton flannel, rubber, or plastic mat cover be provided sufficiently large to cover the mat proper and all supplementary mats. This cover should be stretched tightly and be held in place by ropes, or tape fastening the mat cover to the under side of the supplementary mats, or by lacing the cover underneath the mats. The wrestling area should be marked on the mat cover by painted lines two inches in width. At the center of the mat proper there shall be similarly painted a circle ten feet in diameter. Whenever the match is started or resumed, the contestants shall be within this circle and throughout the match contestants are expected to wrestle within this circle so far as possible. There shall be placed at the center of the cover a design, at least twelve inches long, perpendicular to and pointing away from the timer's table. This design designates the place where matches are to start and the direction wrestlers are to face when starting the wrestling from the referee's position on the mat.

Costume**SECTION 2. The costume shall consist of:**

a. Full length tights and close fitting outside short trunks. Trunks may be worn without the tights if they are fitted so as to prevent unseemly exposure. When trunks are worn without tights shirts shall be required.

b. Light heelless gymnasium shoes reaching above the ankle and laced by means of eyelets.

c. Shirts, if required by the home management. The shirt shall be sleeveless without fasteners at the shoulder and fastened down at the crotch. They shall not be cut away in excess of the shirt illustrated in Figures 1 and 2 (picture of legal shirt, back and front view). The visiting team must be notified in sufficient time to be able to comply with the home team's request. (See Rule 14, Section 3.)

d. It happens occasionally that two contestants look so much alike and are dressed so similarly that it is very difficult for the Referee and spectators to distinguish them. In all dual meets or tournaments, the home management shall have immediately available some provisions for clearly identifying the contestants. Such provisions may be by means of colored anklets, numbers or any other plan which will accomplish the purpose.

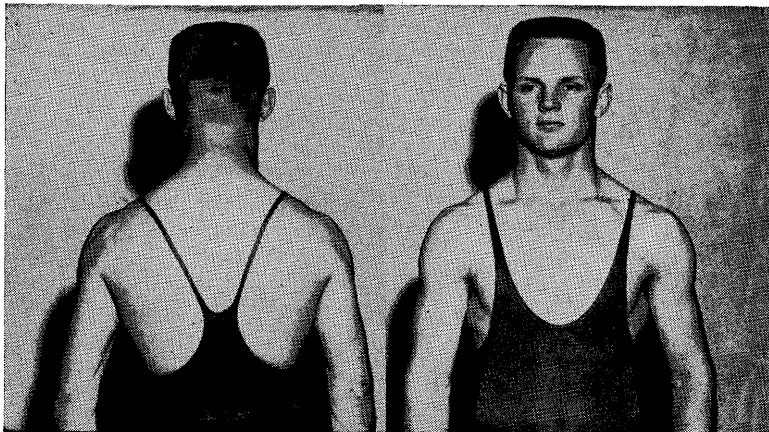

Nos. 1 and 2—FRONT AND REAR VIEW OF SHIRT

This shows the front and rear view of the official shirt.

Headgears SECTION 3. The Wrestling Rules Committee strongly recommends that protective headgear be used in all practice and competition.

Special Equipment SECTION 4. Any mechanical device which does not allow normal movement of the joints and prevents one's opponent from applying normal holds shall be barred. Any legal device which is hard and abrasive must be covered and padded. Loose pads are prohibited.

Enforcement SECTION 5. The legality of all equipment (mats, costumes, helmets, devices, pads, etc.) shall be decided by the referee.

RULE IV—WEIGHT CLASSIFICATIONS

SECTION 1. Competition shall be divided into eight weight classes as follows:

123 lbs.	137 lbs.	157 lbs.	177 lbs.
130 lbs.	147 lbs.	167 lbs.	Unlimited

The 115-lb. and/or 191-lb. classes may be officially included in the weight classification provided either or both are adopted by individual conferences. Interconference meets shall be contested in the original (8) weights.

For the National Collegiate Wrestling Championships the 115 and 191-lb. classes will be included. These weights will count in the scoring of the team championship.

RULE V—WEIGHING-IN AND DESIGNATION OF CONTESTANTS

Time SECTION 1. *a. Tournaments.* Each day of the tournament, except the first day, contestants will weigh-in a maximum of five hours and a minimum of four hours before the meet is scheduled to begin.

For the first day of the National Collegiate Wrestling Championships contestants will weigh-in a maximum of six hours and a minimum of five hours before the meet is scheduled to begin.

b. The contestant who is to represent his institution must be named before the drawings are made.

c. Dual Meets. Contestants may weigh-in a maximum of five hours and a minimum of one-half hour before the meet is scheduled to begin. The exact maximum time shall be decided by mutual agreement of the competing teams. The home team's representative shall be sent onto the mat first, and he cannot be withdrawn or replaced.

d. Supervision. The Referee or other authorized person shall supervise the weighing-in of contestants.

e. Teams may weigh-in on home scales by mutual agreement of coaches and shall furnish the weight list with actual weights listed.

Weight

Allowance

SECTION 2. a. Dual Meets. In all dual meets, net weights shall be required. No overweight is permitted nor should it be requested.

b. Tournaments. In tournaments a one pound allowance shall be given each day over the weight limit of the previous day.

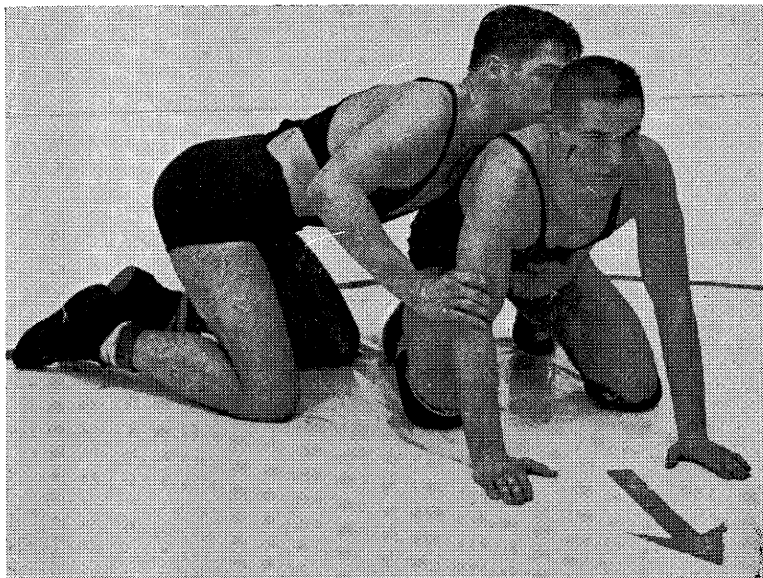

No. 3—LEGAL "REFEREE'S POSITION ON MAT"

This position is shown as required in Rule 8, Section 1, *a* and *b*. Note particularly that offensive wrestler's leg is outside of defensive wrestler's leg.

Failure to Make Weight SECTION 3. Any contestant failing to make weight at the minimum time shall be rejected. If a contestant fails to weigh-in on the second or subsequent day a forfeit shall be awarded his opponent and points for the forfeit and advancement shall be scored.

Medical Examinations SECTION 4. At the time of the weighing-in on the opening day of the annual National Collegiate Championships, a physician or physicians shall be present to examine all contestants for communicable diseases and shall disqualify any contestant who, in their judgment, will endanger other participants. In other meets it is recommended that a medical examination of all contestants be made at the time of the weighing-in, and the presence of a communicable disease or any other condition, which in the opinion of the examining physician makes the participation of that individual inadvisable, should be considered full and sufficient reason for disqualification.

SECTION 5. No substitution is allowed in dual meets or tournaments for injured contestants.

SECTION 6. Defeat due to injury in a tournament does not eliminate a man for third place competition.

RULE VI—CONDUCT OF TOURNAMENTS

Places Scored SECTION 1. In all tournaments four places shall be awarded as follows: The loser in the final first place match shall automatically take second place; the winner of the final consolation match shall be awarded third place and the loser fourth place.

Drawings SECTION 2. Immediately after the expiration of the minimum weighing-in time, drawings shall be made. Drawings shall be made in accordance with the graphic illustrations as provided in Sections 5, 6 and 7 of this rule.

Seeding SECTION 3. Whenever there are two outstanding contestants in any class, the name of one of these contestants shall be placed in the upper half of the drawing bracket and the name of the other in the lower half. In case several seeded men are of equal ability, their seeded positions shall be determined by drawing.

If there is one outstanding wrestler in any class and also two others who are distinctly superior to the remainder in that class, those wrestlers should be seeded in different quarter brackets of the opposite half bracket from the outstanding wrestler. A seeded contestant shall have the same opportunity to draw for the bye as other contestants in his bracket.

In the annual National Collegiate Championships, whenever possible, contestants from the same geographical location or conference who have previously met during the season shall be drawn so as to prevent them from meeting in the first round.

Byes SECTION 4. When the number of competitors is not a power of two (that is, 4, 8, 16, 32, 64) there shall be "byes" in the first round. The number of pairs which meet in the first round shall be equal to the difference between the number of competitors and the next lower power of two. There will be no byes after the first round and no further drawing is necessary for the first place or consolation rounds. The byes, if even

in number, shall be equally divided between top and bottom. If the number of byes be uneven, there shall be one more bye at the bottom than at the top, as shown in Section 5 of this rule.

Any conference or other tournament may be conducted under any bracketing that is agreed upon by the participating schools.

SECTION 5. Graphic Illustration of Drawings and Seeding.

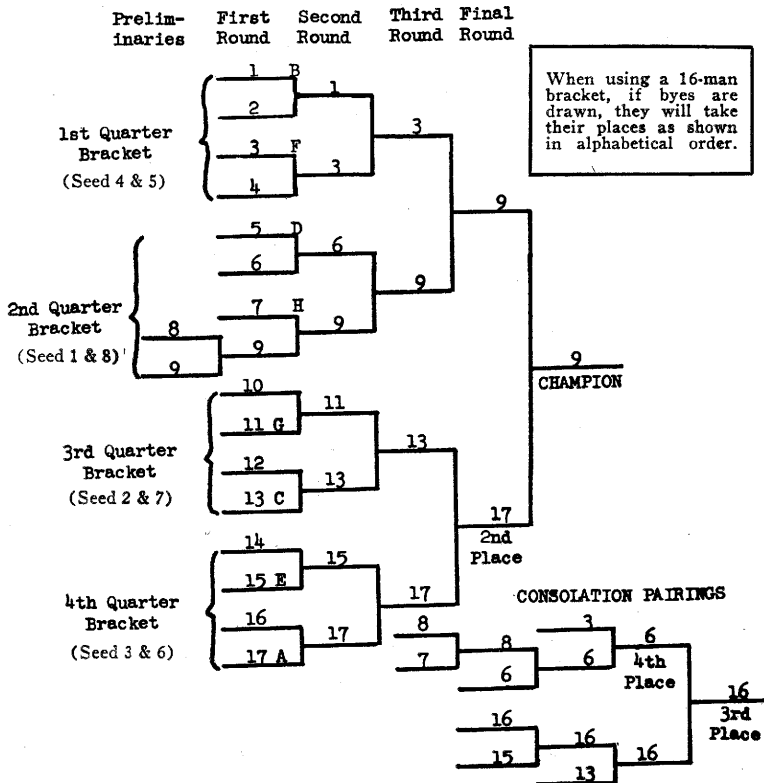

Number 1 seeded man draws for possible positions 5, 6, 7, 8, 9, in 2nd Quarter Bracket.

Number 2 seeded man draws for possible positions 10, 11, 12, 13, in 3rd Quarter Bracket.

Number 3 seeded man draws for possible positions 14, 15, 16, 17, in 4th Quarter Bracket.

Number 4 seeded man draws for possible positions 1, 2, 3, 4, in 1st Quarter Bracket.

Number 5 seeded man draws for position in opposite half of Quarter Bracket #1.

Number 6 seeded man draws for position in opposite half of Quarter Bracket #4.

Number 7 seeded man draws for position in opposite half of Quarter Bracket #3.

Number 8 seeded man draws for position in opposite half of Quarter Bracket #2.

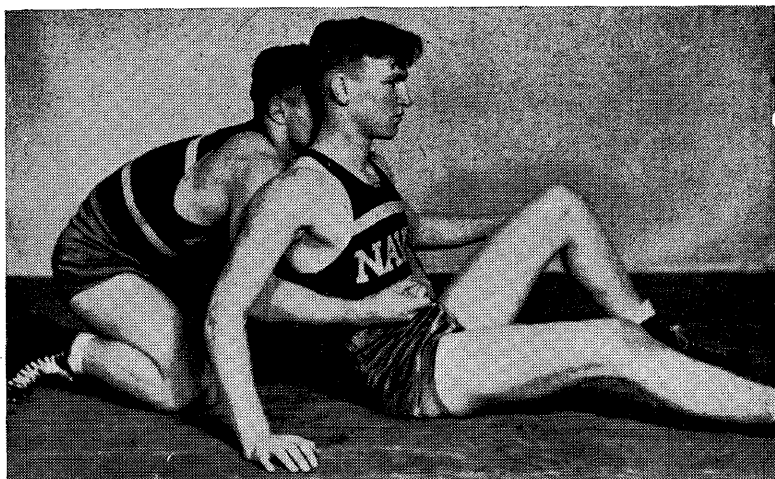

No. 4—INTERLOCKING OF HANDS AROUND THE BODY—A Technical Violation
Offensive wrestler is not allowed to lock hands, wrists or arms around body while defensive wrestler is supported by parts other than his feet.

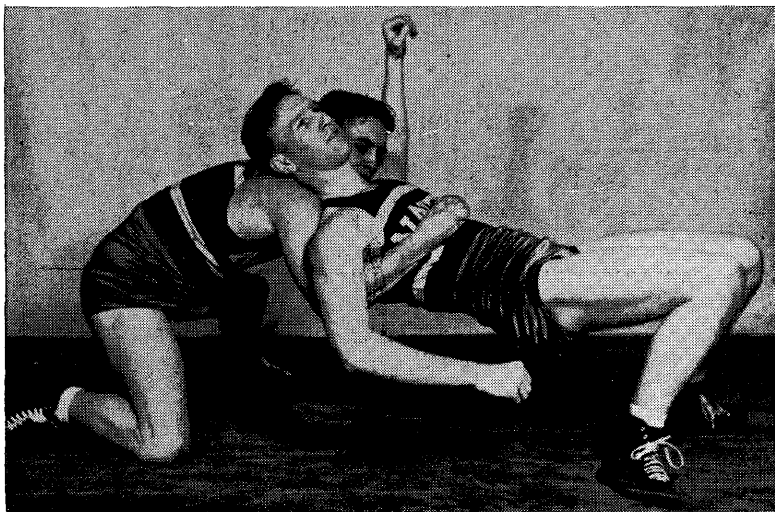

No. 5—LEGAL USE OF THE HANDS IN WAISTLOCK

This shows the legal use of the hands of the top man. The defensive contestant's supporting parts except feet are clearly off the mat.

Contestants Eligible for Third Place Matches

SECTION 6. a. Immediately after completion of the first semi-final match in each weight the third place consolation rounds shall start between all contestants defeated by the winner of this semi-final match. (See b following.)

After completion of the second semi-final match in this same weight the same plan shall be followed as indicated in the preceding paragraph. The winners of the third place consolation rounds in each of the two half-brackets in each weight class, meet in the final consolation match to determine the third and fourth place winner.

b. When only two contestants have been defeated by the winner of any semi-final match the two defeated contestants shall compete and the winner of the match shall meet the corresponding winner from the other half-bracket to decide the third and fourth place awards. When more than two contestants have been defeated by the winner of any semi-final match, preliminary third place matches will be necessary and *should be conducted in accordance with the original first round drawings*; therefore, those eligible for the third place consolations should be matched in the order in which they were defeated by the finalists in this half-bracket. The eligible contestants are designated in Section 6a of this Rule.

Example

SECTION 7. Referring to the Graphic Illustration under Section 5, those eligible for the third place rounds in the upper half-bracket 8, 7, 6, 3, we will assume that 8 wins from 7 and then 6 wins from 8 and 6 defeats 3.

In the lower half-bracket three contestants 16, 15 and 13 have been defeated by the finalist 17 and therefore, only two matches are necessary. We will assume 16 defeats 15 and later defeats 13. He meets 6 in the final consolation match in this weight. The winner 16 is awarded third place and the loser 6 fourth place. All third place matches shall be run off prior to the first place finals matches.

SECTION 8. The Wrestling Rules Committee recommends that medals and team trophies be formally presented in a ceremony made as impressive as possible.

RULE VII—CONDUCT OF MATCHES

SECTION 1. All regular matches shall consist of three three-minute periods. The first period will start with both contestants standing opposite each other and on the 10-foot circle. The wrestlers will come forward, shake hands with the right hand, pass each other, turn to the left at the edge of the circle and, when the Referee blows his whistle, begin wrestling. **A fall during this or either subsequent period terminates the match.** If neither contestant secures a fall in this first period, the Referee shall recess the match and place the wrestlers in the Referee's position (Rule 8, Section 1) with the appropriate contestant in the position of advantage (Rule 7, Section 3). The second three-minute period shall be started immediately by the Referee's whistle. If no fall occurs during this second period, upon its expiration the Referee shall again recess the match, place the contestant who started the second period in the position of advantage underneath and start the third period as before. If no fall occurs during this final period, upon termination of the match the Referee shall award the contest as provided (Rule 8, Section 14 and Rule 7, Section 4).

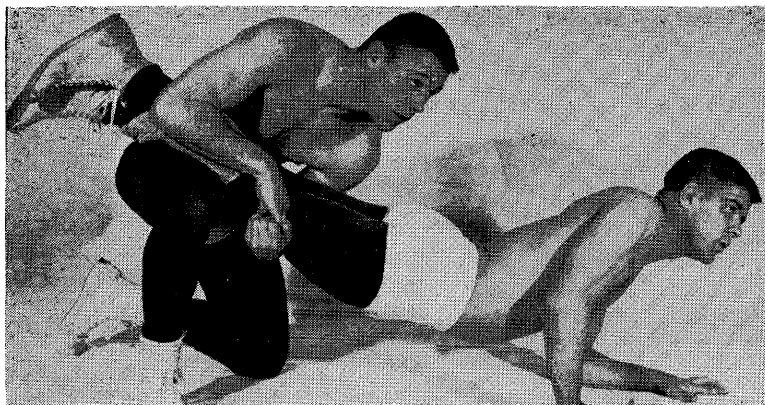

No. 6—INTERLOCKING OF HANDS AROUND LEGS

This position is a technical violation

Intermission SECTION 2. Each recess between the periods of any match shall be only such time as is required by the Referee to bring the contestants into the proper position for the next period. No rest shall be permitted except for injury. (See Rule 12, Section 1.)

Choice of Position SECTION 3. *a. Dual Meets.* Immediately before the contest starts the Referee shall call the captains to the center of the mat and decide by the toss of a coin which team has the choice of position at the start of the second period in each weight class. The winner of a toss may choose the odd or even weight class. A choice of odd or even matches in dual meets is not altered in case of a fall, default or forfeit.

b. Tournament. Immediately following the end of the first period the Referee shall determine which wrestler has the choice of position at the start of the second period, by the toss of a coin.

SECTION 4. *Overtimes.* In tournament competition when there is a tie in points the contestants shall wrestle two extra periods of two minutes each (consolation matches, two periods of one minute each) starting from the referee's position as in the second and third periods of the regular match. The choice of position shall be determined by the toss of a coin. There shall be one-minute rest between the regular match and the first overtime period and no rest between the first and second overtime periods. The points and time advantage are not cumulative throughout the match and overtime periods, and only the points and time advantage scored in the overtime period shall be counted in determining the winner. A jury of two judges and the referee shall observe the overtime periods. When there is a tie in points at the end of the overtime periods the jury shall select the winner by secret ballot without any consultation and the match shall be awarded to the contestant who has shown superior wrestling ability in the overtime periods. The vote of the jury shall be recorded on the score sheet. The criteria for determining superior wrestling ability are attempts to secure falls, takedowns, reversals,

and escapes along with the maintenance of control. Warning penalties recorded in the main match shall be taken into consideration in determining the winner in the overtime.

Consolation Matches SECTION 5. Consolation matches shall consist of three two-minute periods conducted in the same manner as regular matches in tournaments. Overtime periods in consolation matches shall consist of two one-minute periods.

RULE VIII—DEFINITIONS

Referee's Position on the Mat SECTION 1. *a. Defensive Wrestler.* A stationary position in which the defensive wrestler is on his knees facing in the direction indicated by the design with his hands in the center of the mat. He must keep both knees on the mat and they shall not be spread more than the width of the shoulders. The legs must be parallel, with the toes neither turned out or under in an exaggerated position. The heels of both hands must be on the mat not less than 12 inches in front of the knees; and the elbows shall not touch the mat.

b. Offensive Wrestler. The offensive wrestler shall be on his knees at the side of his opponent with his head along the mid line of his opponent's back. The palm of his right (or left) hand shall be placed loosely against the defensive man's navel at the waist line and the palm of his left (or right) hand shall be placed loosely on the back of opponent's left (or right) elbow. Both of his knees shall be on the mat outside of defensive wrestler's near leg. His knee shall not touch the near leg of his opponent and shall be even with or ahead of the defensive man's foot.

Time Advantage SECTION 2. The offensive wrestler who has control in an advantage position over his opponent is gaining time-advantage. A timekeeper assigned to each wrestler records his accumulated

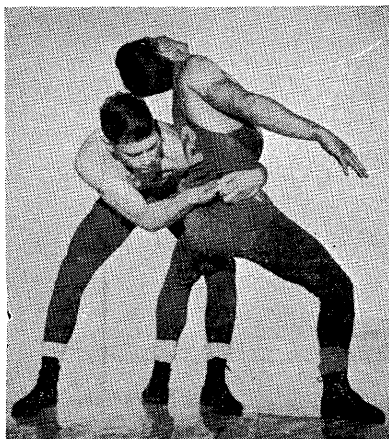

No. 7—LEGAL USE OF HANDS IN BODYLOCK

This complete bodylock is legal because defensive wrestler is in a standing position. This hold would be a technical violation if defensive wrestler had both knees on mat. (See Rule 10, Section 7.)

time-advantage throughout the match or a multiple timer may be permitted to record the time-advantage. At the end of the match the Referee subtracts the lesser time advantage from the greater. If the contestant with the greater time-advantage has less than one minute of net time-advantage, no point is awarded. If he has one full minute or more of net time-advantage, he is awarded *one* point by the Referee. No contestant can be awarded more than *one point* for time-advantage in any one match. The contestant with the lesser time-advantage receives no points even though he accumulates several minutes of time in the advantage position.

Note—Control is a situation in which a contestant exercises and maintains restraining power over his opponent.

Position of Advantage SECTION 3. A position in which a contestant is in control of his opponent. Control is the determining factor. The failure of the offensive wrestler to get his head out from the defensive wrestler's arm does not necessarily prevent the offensive wrestler from having control. The offensive wrestler is entitled to this advantage until such time as his opponent gains a neutral position or a reversal. (See Rule 8, Sections 5, 8, 9 and 10.)

Take Down SECTION 4. Whenever a contestant brings his opponent to the mat and gains control while the supporting points of either wrestler are within the wrestling area he has gained a take-down.

Note—The supporting points of either wrestler are the parts of the body touching the mat that bear the weight of the wrestler's body other than the parts with which he is holding his opponent. When down on the mat the usual points of support are the knees, the side of the thigh and the buttocks. In a standing position the feet are the main points of support.

Out-of-Bounds SECTION 5. Contestants are "out-of-bounds" when any supporting part of either wrestler touches or goes beyond the boundary line with the following exceptions:

a. When a take-down is imminent, wrestling shall continue as long as the supporting points of either wrestler remain within the boundary lines of the wrestling area.

b. When a fall is imminent, wrestling shall continue as long as the head and both shoulders of the defensive wrestler are on the mat proper within the boundary lines.

c. When one wrestler has the advantage position the match shall continue as long as the main supporting parts of either wrestler remain within the wrestling area. If however the referee anticipates a difficult situation at the edge of the mat he may in accordance with Rule 13, Section 11, stop the match and resume the wrestling in the center of the mat.

Resumption of Wrestling After Out-of-Bounds SECTION 6. The position to be assumed by the contestants at the resumption of a match shall be neutral or the Referee's position on the mat as determined by the position held upon going out-of-bounds, except when a penalty involves a change of position. If neither wrestler has control the match shall be resumed with both wrestlers standing opposite each other and on the 10-foot circle. If one wrestler has the advantage position he will take the offensive position on top of his opponent in the Referee's position in the center of the mat.

Stalemate SECTION 7. When the contestants are interlocked in a position other than a pinning situation in which neither wrestler can improve his position nor tries to improve his position, the Referee shall stop the match and wrestling shall be resumed as for out-of-bounds.

Neutral Position SECTION 8. A position in which neither wrestler has control.

Escape SECTION 9. An escape occurs when the defensive wrestler gains a neutral position while the supporting points of either wrestler are within the wrestling area.

Reversal SECTION 10. A reversal occurs when the defensive wrestler comes from underneath and gains control of his opponent either on the mat or in a rear standing position while the supporting points of either wrestler are within the wrestling area.

Fall SECTION 11. Any part of both shoulders or area of both scapula held in contact with the mat for two seconds constitutes a fall. The two-second count (one-thousand-and-one, one-thousand-and-two) shall be a silent count by the Referee and shall start only after the Referee is in such position that he knows positively that a fall is evident, after which the shoulders or scapula area must be held in continuous contact with the mat for two seconds before a fall shall be awarded.

a. A fall shall not be awarded when one or both shoulders or head of the defensive contestant are out-of-bounds. (See Rule 8, Section 5b.)

b. If the defensive wrestler is handicapped by having any portion of his body off the wrestling area, no fall shall be awarded and out-of-bounds shall be declared.

c. When the match is stopped for out-of-bounds in a fall situation, the match shall be resumed in the Referee's position on the mat. (See Rule 8, Sections 1 and 6.)

Near-Fall SECTION 12. A near-fall is a situation in which the offensive wrestler *has control of his opponent in a pinning combination* with both shoulders or the scapula area held in contact with the mat for one full second or when one shoulder of the defensive wrestler is touching the mat, and the other shoulder is held within one inch or less of the mat for two full seconds. Three points shall be awarded for these situations.

Predicament SECTION 13. A predicament is a situation in which the offensive wrestler *has control of his opponent in a pinning combination* and a fall or near-fall is imminent.

a. When both shoulders of the defensive wrestler are held continuously within approximately three inches of the mat, or less, for two full seconds or more, a predicament shall be scored. One point shall be awarded for a predicament.

b. When one shoulder of the defensive wrestler is touching the mat, and the other shoulder is held within an angle of 45 degrees or less with the mat, but not sufficiently close to award a near-fall, for two seconds or more, a predicament shall be scored.

Note 1—A near-fall or predicament is ended when the defensive wrestler gets out of the pinning position and into a position in which a fall is no longer imminent.

The Referee must not signal for score for a near-fall or a predicament until the situation is ended. Only one near-fall or one predicament shall be scored in each pinning situation

regardless of the number of times the offensive wrestler places the defensive wrestler in a near-fall or predicament position during the situation.

Note 2—Regardless of the length of time a defensive wrestler may be held in a pinning combination, no predicament or near-fall may be awarded except as provided in Rule 8, Sections 12 and 13 above.

Note 3—Only a wrestler with the advantage who has his opponent in a pinning hold may score a near-fall or predicament. Bridgebacks in body scissors or bridgeovers with a wristlock are not considered near-fall or predicament situations although a fall may be scored.

Note 4—When the defensive wrestler places himself in a precarious situation during an attempted escape or reversal, a near-fall or predicament shall not be scored unless the offensive wrestler has a pinning hold.

Decisions SECTION 14. If no fall has resulted after expiration of the three regular periods of any match as provided in Rule 7, Section 1, the Referee shall award the match to the contestant who has scored the greater number of points as provided by the point system in Rule 9, Section 2. If there is a tie in the number of points scored, the Referee shall declare the match a draw in dual meets. See Rule 7, Section 4 for tournaments.

Forfeit SECTION 15. A forfeit is received by a wrestler when his opponent for any reason fails to appear for the match. In order to receive a forfeit, a wrestler must be dressed and appear on the mat.

Default SECTION 16. A default is awarded in a match when one of the wrestlers is unable to continue wrestling due to an injury, a disqualification or for some other cause.

RULE IX—SCORING

Team Score SECTION 1. *a. Dual Meet.*

(1) *Fall.* Five points shall be scored toward the team total for each contestant who wins by a fall, default or forfeit.

(2) *Decision.* The decision shall count three points on the team score.

(3) *Draw.* In case of a tie two points shall be scored for each team.

b. Tournaments. In tournaments, first place in each weight class shall count 10 points, second place 7 points, third place 4 points and fourth place 2 points. One additional point shall be scored for each match won by a fall, default or forfeit throughout the tournament. In addition one point shall be scored for each match won in both the championship and consolation eliminations except for the final first and third place matches. No points are awarded for a bye.

Match Point Score System SECTION 2. In all matches the contestants are awarded points by the Referee in accordance with the following system:

Take-Down (Rule 8, Sec. 4)	2 points
Escape (Rule 8, Sec. 9)	1 point
Reversal (Rule 8, Sec. 10)	2 points
Near-Fall (Rule 8, Sec. 12)	3 points
Predicament (Rule 8, Sec. 13)	1 point
Time Advantage (Rule 8, Sec. 2)	1 point for one full minute or more of net accumulated time in the advantage position. <i>One</i> point is the maximum to be awarded for the match.
Penalties (Rule 11, Penalty Chart)	

SUMMARY OF SCORING

<i>Individual Match Points</i>	<i>Dual Meet Points</i>	<i>Tournament Points</i>
Take-Down . 2 pts.	Fall	1st Place
Escape 1 pt.	Forfeit	2nd Place
Reversal ... 2 pts.	Default	3rd Place
Near-Fall .. 3 pts.	Decision	4th Place
Predicament 1 pt.	Draw	Fall
Time Advantage 1 Pt. (maximum for one or more minutes)		Default
		Forfeit
		*Advancement .. 1 pt.

* See Rule 9, Sec. 1b

RULE X—INFRACTIONS

Illegal Holds

SECTION 1. Any hold shall be allowed except the hammer lock above the right angle; the twisting hammer lock; front headlock; the straight head scissors (even though the arm is included); over-scissors; flying mare with the palm up; full (double) nelson; strangle holds; all body slams; toe holds; twisting knee lock; the bending, twisting or forcing of the head or any limb beyond its normal limits of movement; locking the hands in a double arm bar from a neutral position; and any hold used for punishment alone.

Note 1—Contestants may grasp all four fingers in an effort to break a hold, but pulling back the thumb, or one, two or three fingers is illegal.

Note 2—The term "slam" is interpreted as lifting and bringing an opponent to the mat with *unnecessary roughness*. This infraction may be committed by a contestant in either the top or bottom position on the mat as well as on a takedown. A contestant who lifts his opponent clear of the mat is responsible for the safe return of that opponent to the mat. A forceful trip is not interpreted as an illegal slam providing the defensive wrestler is not lifted completely off the mat.

Note 3—A leg hooked over the top toe of an opponent's straight body scissors is interpreted as an over-scissor and therefore illegal.

Note 4—A wrestler applying a legal hold should not be penalized when his opponent turns the legal hold into an illegal hold. The Referee shall cause the hold to be released if there is danger of injury. However, the match need not be stopped unless the Referee finds it necessary to do so in order to correct the situation.

Note 5—Whenever possible an illegal hold should be prevented rather than called.

**Unnecessary
Roughness**

SECTION 2. Intentional striking, gouging, kicking, hair pulling, butting, elbowing or any intentional act that endangers life or limb shall be grounds for disqualification on first penalty

if the referee considers such act as flagrant misconduct. The referee shall follow the penalty chart for the penalties in the case of less flagrant unnecessary roughness. (See Penalty Chart on Page 76.)

Foreign Substance on Skin SECTION 3. The use of oil or greasy substances which cannot be completely removed shall be grounds for disqualification at the discretion of the Referee. Time out for the removal of such foreign substance shall be cumulative with the time out for injuries throughout the match. The total time out shall not exceed three minutes. (See Rule 12, Section 1.)

Objectional Pads and Braces SECTION 4. (See Rule 3, Section 4 and the Penalty Chart.)

Abusive Conduct SECTION 5. Conduct of a coach, contestant, or spectator that becomes abusive or interferes with the orderly progress of a match shall be grounds for removal from the premises. The home management shall be responsible for the removal of the violators at the request of the Referee. (See Penalty Chart.)

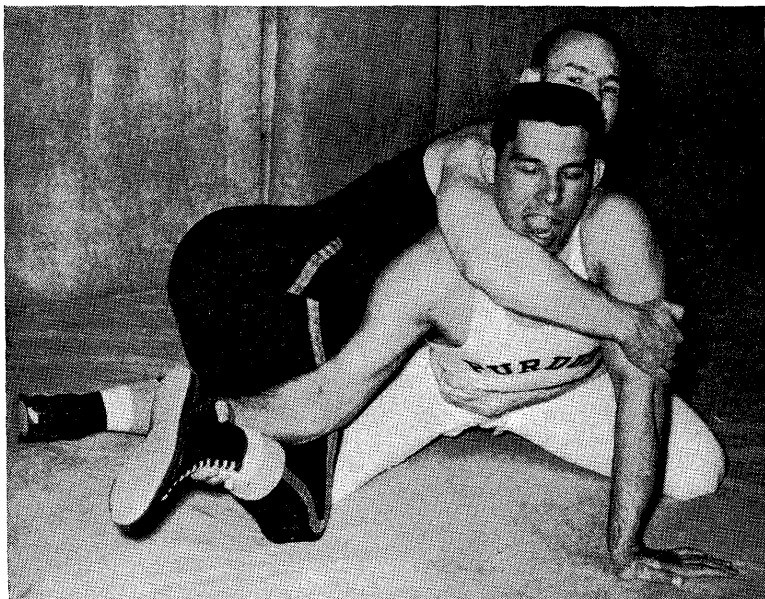

No. 8—ILLEGAL TWISTING KNEE LOCK

This shows the start of a twisting knee lock. If the leg is forced further this will become an illegal hold (Rule 10, Section 1). The Referee should anticipate the danger of injury from this hold and be in a position to block it before it reaches the danger point.

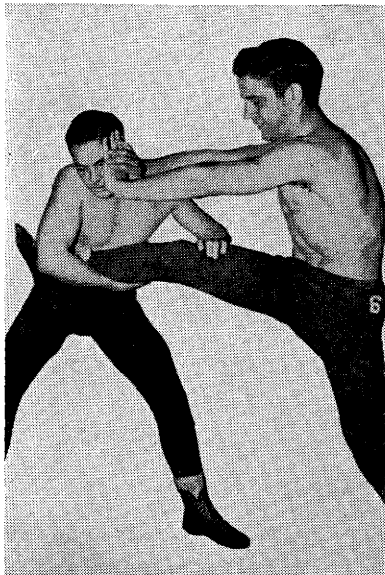

No. 9—LEGAL BLOCKING ON
FACE (ON CHIN)

Blocking on chin or forehead is legal but is not legal over face proper; that is, over mouth, nose or eyes.

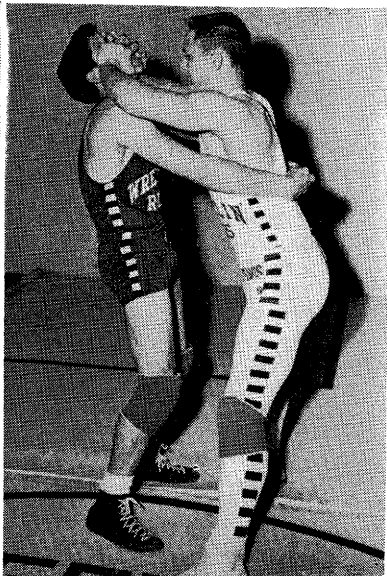

No. 10—ILLEGAL BLOCKING ON
FACE (ON FACE PROPER)

This form of blocking is illegal because it is over mouth, nose and eyes, in contrast to position in No. 8.

Potentially

Dangerous Holds

SECTION 6. The double wristlock, chicken wing, key lock, overhead double bar lock and other holds may cause injury when used legally, and are potentially dangerous holds. Contestants should know the dangers of these holds and the blocks for them. The Referee should anticipate danger of injury from these holds and be in position to block them before they reach the danger point. Furthermore, all Referees, coaches and contestants should understand that any and all holds used in such a way as to endanger life or limb are illegal and all Referees should verbally caution contestants against forcing a potentially dangerous hold into an illegal position. The double wristlock and chicken wing become illegal when forced into a twisting hammer lock position as in the case of applying the force parallel instead of perpendicular to the long axis of the body.

It should be understood that no contestant should ever be put in a position where he must forfeit a neutral position, a position of advantage or a fall because of an injury or danger to life or limb, and the Referee should promptly stop any and all holds which in his opinion may so result. If a legitimate hold is forced to such an extent as to endanger a contestant or if it becomes a punishing hold, the Referee shall stop the match and require the hold to be broken. The match shall be resumed in the neutral or Ref-

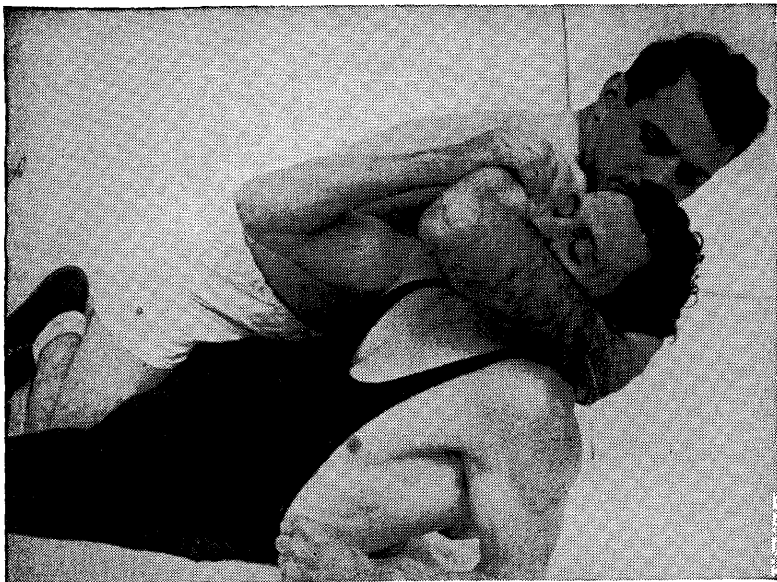

No. 11—ILLEGAL FACE HOLD

Shows a hold commonly used but which is contrary to both the letter and spirit of amateur wrestling rules. It is frequently used momentarily in order to prevent defensive wrestler from coming out from underneath or to bring defensive wrestler back into position for a fall. Referee should see that offensive wrestler does not secure unfair advantage by means of this illegal action.

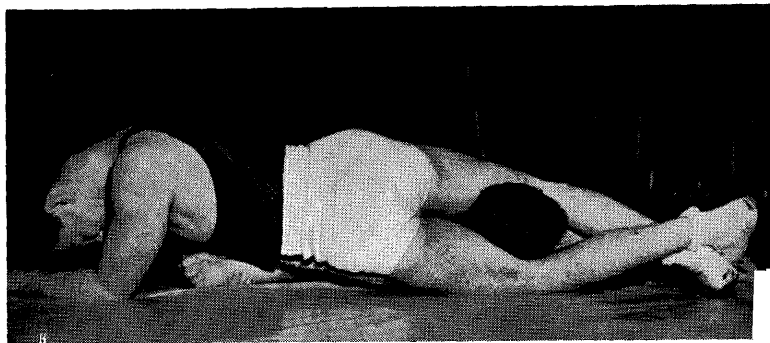

No. 12—ILLEGAL HEAD-SCISSORS

This hold is illegal. All straight scissors on the head are illegal.

eree's position as determined by the position held at the time the match was stopped unless a penalty involves a change of position.

a. Any holds over the mouth, nose, eye or front of throat shall not be permitted. Pressure from the side of the hand, forearm or wrist is considered a hold and therefore barred when used on the mouth, nose, eyes or front of throat. Forcing such a hold may be considered unnecessary roughness depending on the intent of the act as determined by the Referee and shall be penalized accordingly.

Technical Violations

SECTION 7. a. *Interlocking Hands.* Interlocking of fingers, hands or arms, around the body or both legs by the offensive contestant while on the mat is a technical violation. This has reference only to the wrestler in the position of advantage on the mat and does not apply when the defensive man has gained his feet or when the lock is used as a pin hold. Interlocking of fingers, hand or arms is permitted when the defensive man is standing. The mere touching of the defensive man's hands to the mat is not considered a change in this position unless the hands are used as supporting parts, in which case, the offensive contestant is allowed reaction time to release the lock. It is unsportsmanlike for the defensive contestant to touch his hands to the mat in order to release the offensive wrestler's lock and the Referee shall not call a violation if the lock is held in such cases.

Note—The Referee shall not call this violation when the defensive man is in the process of a reversal. The defensive man is allowed to complete the reversal provided he does so in one continuous maneuver. If the defensive man fails to complete the reversal after an opportunity to do so then the Referee will stop the match and award the penalty. (See Penalty Chart.)

b. *Holding Legs.* It is a technical violation for the wrestler in the advantage position on the mat to grasp the defensive wrestler's leg or legs with both hands or arms unless such action is designed to break his adversary down and go into a pinning combination or to prevent an escape or reversal. Repeatedly grasping and holding the leg or legs with both hands or arms merely to break the defensive wrestler down or to keep him under control for the purpose of stalling is a violation under this rule. When the defensive wrestler has gained his feet the wrestler in the advantage position is allowed reaction time to begin his break down when he is holding a leg or legs with both hands or arms.

c. *Leaving Mat Without Permission.* It is a technical violation to leave the mat without first receiving permission to do so from the Referee.

d. *Delaying Match.* Delaying the match such as straggling back from out-of-bounds, unnecessary changing and adjusting equipment, repeatedly assuming incorrect referee's position and repeatedly making false starts from the referee's position are technical violations.

e. *Intentional Forcing Opponent Off Mat.* Intentional forcing opponent off the mat to prevent a take-down, reversal or an escape is a technical violation. If the contestant pushes his opponent off the mat to keep him from getting clear or from going behind, the Referee shall bring both men to their feet at the center of the mat if he believes this action has simply prevented the defensive wrestler from gaining a neutral position, but if he believes the defensive wrestler would have gone behind his opponent had the violation not occurred, he shall give the defensive wrestler the offensive position in the Referee's position on the mat. Points are awarded according

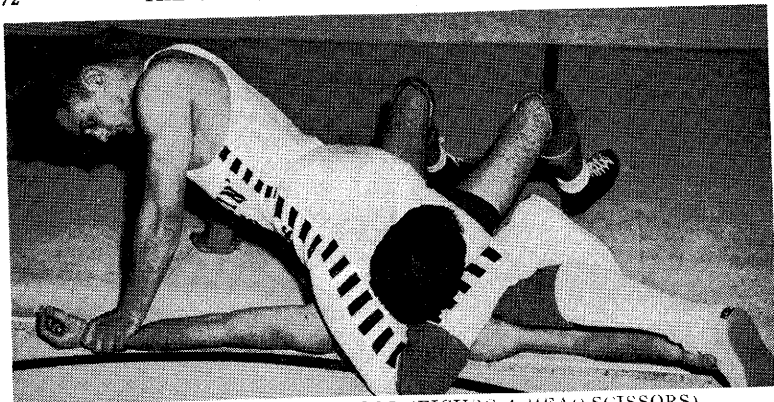

No. 13—LEGAL HEAD-SCISSORS (FIGURE 4 HEAD-SCISSORS)

The straight head-scissor is illegal. The figure 4 Head-Scissor is considered legal when taken as shown above, with the hold on either side of the face.

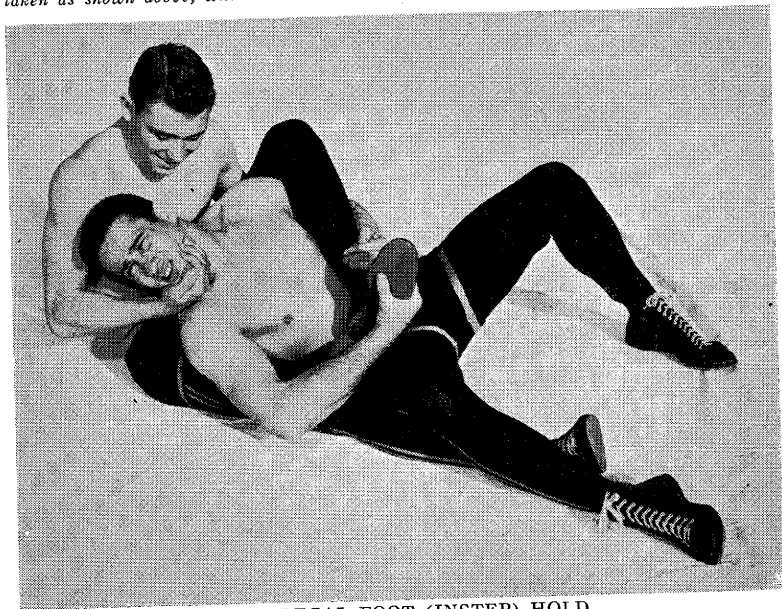

No. 14—LEGAL FOOT (INSTEP) HOLD

The defensive wrestler is allowed to grasp instep, heel or ankle to break such holds as body-scissors, leg-ride, etc., provided the foot is not drawn up to the point where, in the opinion of the Referee, it endangers knee or hip-joint.

to the position given.

f. Intentional Going Off Mat. Intentionally going off the mat to prevent a take-down, reversal or escape is a technical violation. If in the opinion of the Referee, a contestant intentionally runs, slides, crawls or rolls off the mat to prevent his opponent from going behind him, the Referee shall immediately give his opponent the advantage in the referee's position on the mat. If the violation prevented an escape or reversal, the Referee shall immediately give his opponent the escape or reversal and award points according to the change of position.

g. Defensive Wrestler Intentionally Going Off Mat. It is a technical violation if the defensive wrestler intentionally walks, crawls, rolls or bridges off the mat. No penalty is provided if a near-fall or predicament is awarded during this violation.

Note—It is considered a violation if the contestant in a figure-four body scissors intentionally goes off the mat to get the hold released.

h. Stalling. It is the responsibility of both contestants to maintain action throughout the match by making an honest attempt to stay in the circle and wrestle aggressively whether in the top, bottom or neutral positions.

(1) *Neutral Position.* Each wrestler must make an honest attempt to stay in the circle and secure a take-down regardless of the time or score of the match. A contestant who continually avoids contact with his opponent by moving out of the circle is stalling. A contestant may leave the circle to maneuver for position provided he continues his attempt to gain an advantage and makes an effort to work back into the circle. Taking a position

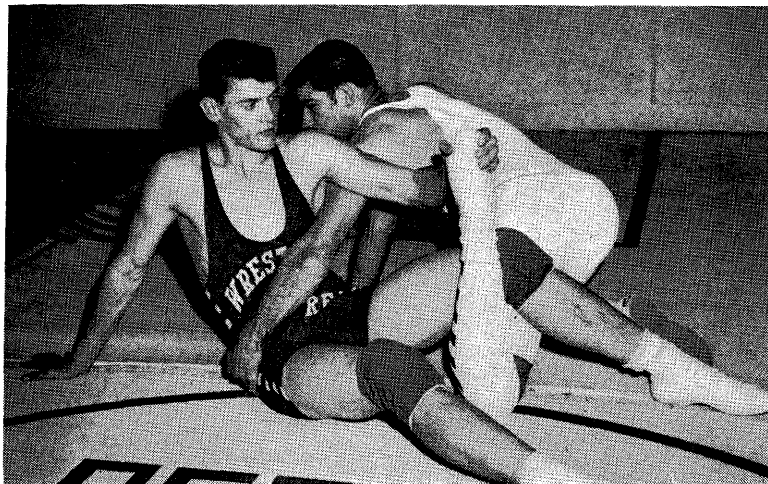

No. 15—ILLEGAL TOEHOOLD (ALSO TWISTING KNEELOCK WHICH IS MORE DANGEROUS THAN TOEHOOLDS)

All toeholds, regardless of the degree to which the leg is twisted are illegal under these rules. Any pressure against the knee joint as shown by the above illustration constitutes an illegal hold.



No. 16—OVER-SCISSORS (AN ILLEGAL HOLD)

The over-scissors is barred entirely under these rules because it is only a punishing hold and is of no value unless defensive contestant who uses it is allowed to force the hold, which thereby endangers the ankle and knee of his opponent.

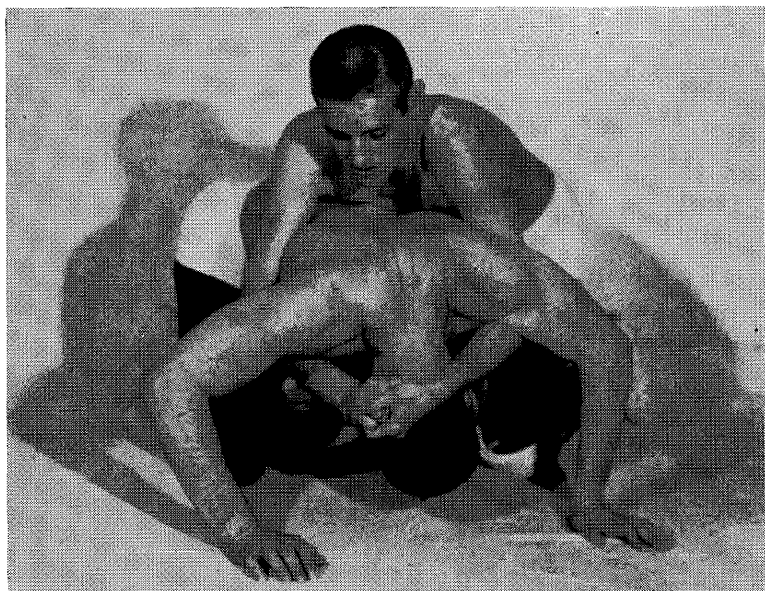

No. 17—FULL NELSON—AN ILLEGAL HOLD

Most of the difficulty has arisen when the three-quarter is confused with the full nelson. In the full nelson the aggressor places both arms under his opponent's arms and clasps his hands or wrists on the back of his opponent's head.

near the edge of the mat for the purpose of going off the mat, or allowing his opponent to push him off when the opponent makes an effort to go behind, is stalling.

(2) *Advantage Position.* The contestant in the advantage position on the mat shall make an honest attempt to wrestle aggressively. A period of thirty seconds should be sufficient time for the Referee to decide whether or not a contestant retaining a stalling hold has made an attempt to improve his position. For the second and subsequent penalties a period of fifteen seconds should be sufficient time to determine the intent to stall.

Note—Any legal hold is not to be construed as a stalling hold if in the opinion of the Referee the offensive wrestler has a fair chance to pin his opponent and is making a real effort to do so.

(3) *Defensive Position.* Lying on the stomach and refusing to wrestle is stalling in the defensive position and shall be penalized as a technical violation. (See penalty chart.) The stalling penalty shall not be invoked when the defensive contestant is on his knees.

i. *Grasping Clothing, etc.* No grasping of clothing, mat or mat cover by a contestant is permitted and any advantage gained thereby shall be nullified. Grasping clothing to prevent an escape, reversal, takedown or fall, is a technical violation.

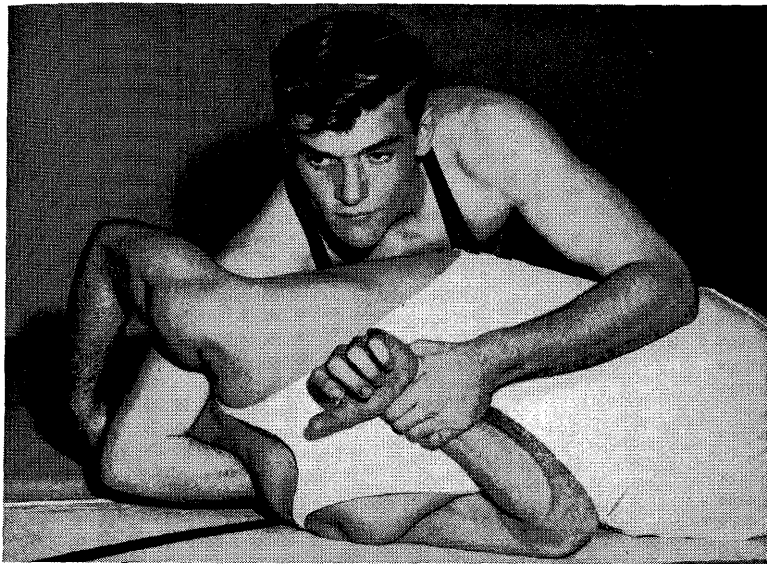

No. 18—ILLEGAL HAMMERLOCK (ABOVE RIGHT ANGLE)

The hammerlock is a legal hold, provided the arm is not bent above the right angle (i.e., provided that the arm is not carried above the small of the back); and provided, further, that the hand is not forced out away from the body, making it a twisting hammerlock. In this illustration the arm is carried distinctly above the right angle and is dangerous.

PENALTY CHART

Infractions	Position of Offender	First Penalty	Second Penalty	Third Penalty	Rule 10 Sections
ILLEGAL HOLD AND/OR UNNECESSARY ROUGHNESS (3 PENALTIES DISQUALIFY) (See Rule 11, Sec. 3A)	Neutral	2 pts. N.C.	2 pts. T.D.	Disqualify	1
	Advantage	2 pts. N.C.	Final Warning 2 pts. R.	Disqualify	2
	Defensive	2 pts. N.C.	Final Warning 2 pts. N.C.	Disqualify	
FLAGRANT MISCONDUCT	Disqualification on first penalty			2
ABUSIVE AND/OR UNSPORTSMANLIKE CONDUCT (See Rule 13, Sec. 16)	Warning	Deduct 1 team pt.	Removal from premises by home management	5
GRASPING CLOTHING, MAT OR MAT COVER	Any advantage shall be nullified				
	Advantage	2 R or 1 N	2 R. or 1 N.	2 R. or 1 N.	7i
	Neutral	2 pts. T.D.	2 pts. T.D.	2 pts. T.D.	
	Defensive	1 pt. N.C.	1 pt. N.C.	1 pt. N.C.	
GREASY SUBSTANCE ON SKIN AND/OR OBJECTIONAL PADS AND BRACES	Disqualify if it cannot be removed in allotted time			3 4
	TECHNICAL VIOLATIONS:				
Interlocking of hands around body, holding leg or legs with two hands or arms.	Advantage	1 pt. N.	1 pt. N.	1 pt. N.	7a 7d
Leaving mat without permission or delaying match. (First penalty is not a stalling warning.)	Warning	1 pt. N.C.	1 pt. N.C.	7c 7d
Stalling (only one first penalty regardless of position. See Rule 11, Sec. 3B)	Neutral	1 pt. N.C.	2 pts. T.D.	2 pts. T.D.	7h1
	Advantage	(1 Warning only for match)	1 pt. N.	1 pt. N.	7h2
	Defensive		1 pt. N.C.	Disqualify	7h3
Intentional running, crawling or sliding off the mat; or pushing, pulling or carrying an opponent off mat to prevent a change in position.	Neutral	2 pts. T.D.	2 pts. T.D.	2 pts. T.D.	7e
	Advantage	2 pts. R. or 1 pt. N.	2 pts. R. or 1 pt. N.	2 pts. R. or 1 pt. N.	7f
Intentional going off mat (not given if near-fall or predicament points awarded).	Defensive	1 pt. N.C.	1 pt. N.C.	1 pt. N.C.	7g

Key: T.D.—takedown, R—reverse, N—neutral, N.C.—no change.
It is suggested that this chart be incorporated in your dual meet program.

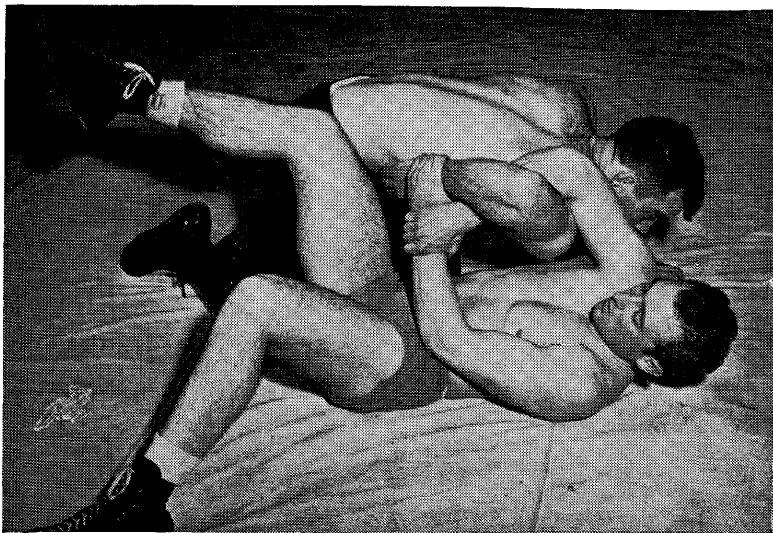

No. 19—LEGAL DOUBLE WRISTLOCK ON THE MAT

The double wristlock on the mat is legal if the direction of the force is perpendicular to the long axis of the body.

RULE XI—PENALTIES

SECTION 1. The infractions of the rules are penalized in accordance with the penalties as listed on the Penalty Chart. (Page 76.)

SECTION 2. In calling each penalty the Referee shall stop the match, give the hand signal for the points or warning (pages 86 and 87) and announce the penalty so that the contestants, scorers, coaches and spectators are aware of it.

Sequence of Penalties

SECTION 3. a. Illegal Holds or Unnecessary Roughness. Each contestant has only one First Penalty, Second Penalty and Third Penalty for illegal action regardless of whether he is in the neutral, advantage or defensive position. He does not get two penalties from each position before disqualification. The penalties are cumulative throughout the match including the overtimes regardless of position and the offender shall be disqualified on the third penalty when he has a series of three illegal infractions.

b. Penalty for Stalling. Each contestant has only one First Penalty for stalling regardless of whether he is in the neutral, advantage or defensive position. He does not get a first penalty in each position. The stalling penalties are cumulative throughout the match *including overtime* regardless of the position in which they occur and the second and third infractions shall be penalized as indicated on the Penalty Chart.

c. Third and Subsequent Penalties. Third and subsequent penalties for technical violations other than defensive stalling are the same as the second penalty in each case.

RULE XII—INJURIES AND DEFAULTS

SECTION 1. An injured contestant has a maximum time-out of three minutes which is cumulative throughout the match including the overtime. Nose bleed shall not be interpreted as an injury and the number and length of time-out periods for nose bleed is left to the discretion of the Referee. There shall be no limit to the number of time-out periods which may be taken in any match, but the total time-out shall not exceed three minutes. If, at the expiration of the time-out, he is able to continue wrestling, the match shall be resumed as if the contestants had gone out-of-bounds.

If a contestant is rendered unconscious he shall not be permitted to continue the match without the approval of a physician. If the injured contestant is unable to continue wrestling, the match shall be awarded in accordance with Sections 2 and 3 of this Rule.

Accidental Injury **SECTION 2.** If a contestant is accidentally injured and is unable to continue the match, his opponent shall be awarded the match by fall.

Injury from Illegal Action **SECTION 3.** If a contestant is so injured by any illegal action that he is unable to continue, the match shall be defaulted to the injured contestant and shall be scored as a fall. In case of an intentional attempt to injure an opponent, the offender shall be disqualified. (See Rule 10, Section 2 and Penalty Chart for "Unnecessary Roughness.")



No. 20—ILLEGAL DOUBLE WRISTLOCK ON THE MAT

This cut shows double wristlock turned into a typical twisting hammerlock that will injure opponent's shoulder if the arms are forced upward, unless opponent turns with the pressure, which often he is unable to do promptly enough to prevent injury to the shoulder.

Attendants During Time-Out SECTION 4. No more than two attendants and a physician shall be permitted on the mat with a wrestler during time-out.

RULE XIII—OFFICIALS

Referee's Duties SECTION 1. On matters of judgement the Referee shall have full control of the meet and his decisions shall be final and without appeal. On matters of a technical nature, the current NCAA Rules shall be the final authority.

SECTION 2. Before the contestants come to the mat the Referee shall:

- Inspect contestants for presence of oils or greasy substances, rosin, objectionable pads, improper clothing, finger rings, long finger nails, etc.
- Clarify the rules with coaches and contestants.
- Advise contestants to report to edge of the circle at the center of the mat opposite each other ready to wrestle.

SECTION 3. The referee is responsible for the seating arrangement at the officials table in accordance with one of the diagrams below:

WHEN INDIVIDUAL CLOCKS OR STOP WATCHES ARE USED

Home Team Assistant Timekeeper	Visiting Team Assistant Timekeeper	Match Timekeeper	Visiting Team Scorer	Home Team Scorer
--------------------------------------	--	---------------------	-------------------------	---------------------

WHEN MULTIPLE TIMER IS USED

Timekeeper	Visiting Scorer	Announcer or Home Scorer
------------	-----------------	--------------------------

SECTION 4. Instruct the match timekeeper that he is:

- In charge of assistant timekeepers, and scorers, and should be constantly checking their activities at all times.
- Responsible for keeping the over-all time of the match.
- Responsible for recording accumulated time-outs for injury.
- Responsible for informing the Referee, only after an imminent situation has passed, whenever there is disagreement by the official scorers and/or timekeepers.
- Responsible for assisting the Referee in determining whether a situation occurred before or after the termination of a period.
- Responsible for calling the minutes to the Referee, contestants, and spectators in each match. The last minute shall be reported at fifteen second intervals.

Note—The Home Institution shall provide each timekeeper with an accumulative time clock for recording the time during the match. The match timekeeper shall be provided with two extra accumulative time clocks for recording time out in case of injury to the contestants. The match timekeeper shall also be provided with a gong, horn, or bell.

A multiple timer may be used in place of time clocks.



No. 21—ILLEGAL FRONT HEAD LOCK

This cut shows how the front head lock is used to counter a leg pickup. This hold is dangerous and is illegal.

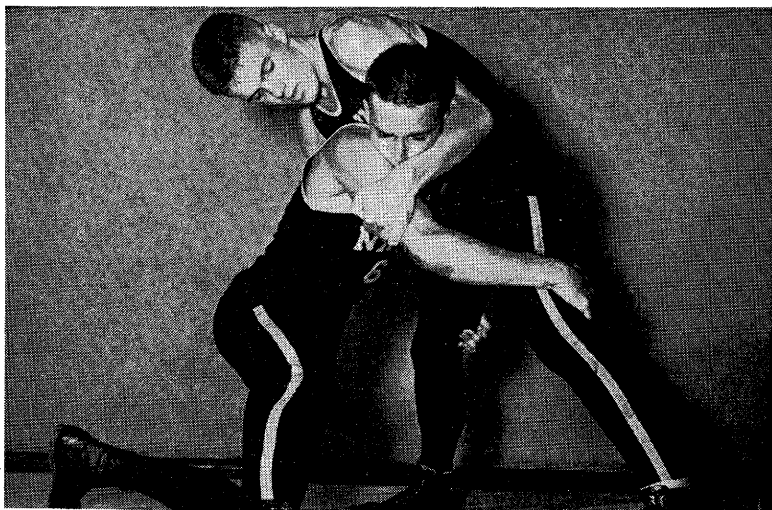

No. 22—A LEGAL CROSS FACE

It is an effective and legal block for the double leg pickup.

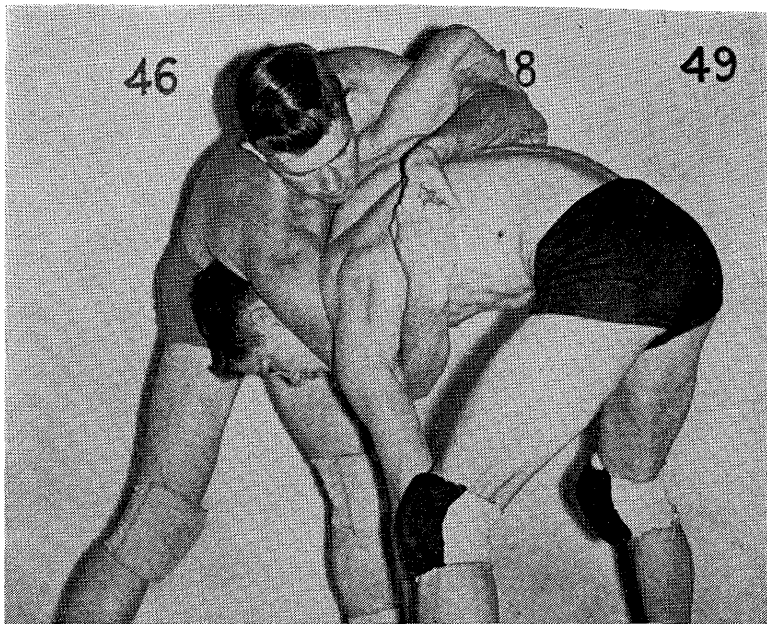

No. 23—ILLEGAL DOUBLE ARM BAR

Locking hands in a double arm bar from a neutral position.

SECTION 5. Instruct the assistant timekeepers that they are responsible for :

- a. Recording the accumulative time advantage of the contestants, to whom they have been assigned when indicated by the Referee.
- b. Constantly checking each other's time advantage recording.
- c. Constantly checking the match timekeeper's time recording.
- d. Showing the Referee the stop clock recording of the time advantage each contestant has accumulated at the end of the match.

SECTION 6. Instruct the scorers that they are responsible for :

- a. Recording which contestant has the position of advantage at the start of the second and third periods.
- b. Recording points scored by both contestants when signaled by the referee.
- c. Constantly checking each other's score reading.
- d. Immediately advising the match timekeeper when they are in disagreement regarding the score.

e. Keeping the score board operator continually advised of the official score during each match.

f. Showing the Referee the scorecard at the end of each match.

SECTION 7. Before the dual meet starts call the team captains to the center of the mat for the toss of the coin to determine the choice of position at the start of the second period. (Rule 7, Section 3.)

SECTION 8. The Referee will use the Wrestling Officials Signals.

SECTION 9. The Referee shall notify the timekeepers as follows:

a. When the match is started or stopped for any reason.

b. When time advantage begins or ends for a contestant.

c. Whenever time is involved in any situation occurring in the match.

SECTION 10. The Referee shall notify the scorer, when warnings or points are awarded to either contestant. (See Signals for Referees.)

SECTION 11. The Referee should anticipate difficult positions on the edge of the mat and prevent them by stopping the match, and resume wrestling at the center of the mat, as in the case of an off-mat decision.

SECTION 12. The Referee shall be firm in enforcing the letter and spirit of the rules and penalize consistently any repeated infractions. He must enforce vigorously and promptly the penalties for the infractions as provided in Rules 10 and 11. On each penalty the referee shall stop the match and announce the penalty in the prescribed manner so that the contestants, scorers, coaches and spectators are aware of it. (See Signals for Referees.)

SECTION 13. The Referee shall caution the user of a potentially dangerous or illegal hold in order to prevent possible injury. Such holds should be stopped by the Referee, if possible, before reaching the dangerous stage.

SECTION 14. The Referee should not place his hands under the shoulders of a contestant unless absolutely necessary to determine a fall.

SECTION 15. The Referee should meet promptly, in a spirit of good sportsmanship, any situation developing unexpectedly.

SECTION 16. If the conduct of a coach, contestant, or a spectator interferes with the orderly progress of the match, the home management shall be responsible, at the request of the Referee, for the removal of the offender from the premises. (See Penalty Chart.)

SECTION 17. At the end of a match the referee shall order the contestants to shake hands and raise the hand of the winner. If there is a doubt as to the winner the Referee shall order the contestants to stay on the mat while he checks the time advantage and the scorer's records to decide the winner. The time advantage, if any, shall be recorded on the score board and the referee shall declare the winner in accordance with the instructions in the first sentence of this section. In dual meets, if the match is a draw the referee will raise one hand of each wrestler.

Note 1—If in the opinion of the Referee there is an error in the recordings of the timekeepers and/or scorers, the Referee shall correct the error and render his decision accordingly.

Note 2—In overtime periods if the points are even the referee and two judges shall determine the winner by secret ballot.

RULE XIV—NOTIFICATION AND AGREEMENT OF MEETS

Equal Rights for Visiting Teams SECTION 1. All modifications of rules of competition, "ground rules," etc., proposed by the home manager, must be submitted to the manager of the visiting team, or teams, a sufficient length of time before date of meet for agreement to be reached on same, and no such action is binding unless approved by the visiting team or teams.

SECTION 2. In dual meets the selection of a Referee and the maximum weighing-in time shall be mutually agreed upon at least ten days prior to date of meet.

Note—In case the Coaches concerned are unable to agree on a shorter maximum weighing-in time than the five hours specified as the maximum in these rules, it is understood that the maximum amount of time as specified in the rules shall hold.

SECTION 3. The home management shall notify visiting teams at least ten days prior to date of meet the exact time and place of the meet, the name of the referee, and if shirts will be required.

RULE XV — REFEREES' SIGNALS

The signals illustrated on the following pages are standard for wrestling referees throughout the nation. It is the duty of every referee to know these signals in order to give them instantly and clearly so that the wrestlers, timers, scorers and spectators are aware of what is taking place during the progress of the match.

SECTION 1. Referee's attire for the National Collegiate Wrestling Championships:

- a. White long sleeved dress shirt.
- b. White full length trousers.
- c. White sox and black gym shoes.
- d. Black belt.

Other accessories—silver dollar and whistle.

The Use of the Whistle

SECTION 2. The whistle should be held ready for immediate use at all times during the match.

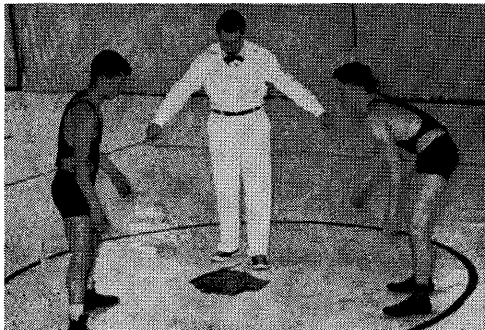

Fig. 1. DESIGNATING THE POSITIONS OF THE WRESTLERS BEFORE THE START OF THE MATCH. As the wrestlers come onto the mat the referee points to the places they are to take inside the circle. He next points one hand toward the timers and scorers to verify their readiness.

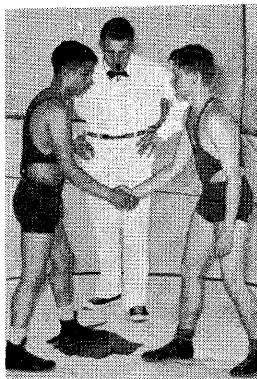

Fig. 2. (top left) SHAKING HANDS AND PASSING BY. After the officials indicate they are ready at the table, the referee directs the wrestlers to shake hands, pass by and be ready to wrestle when the whistle blows. The referee motions for the wrestlers to shake hands and pass by crossing his arms in front of his body.

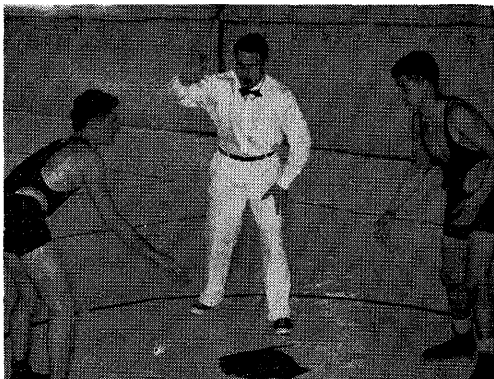

Fig. 3. (top right) STARTING THE MATCH OR RESUMING THE MATCH IN A NEUTRAL POSITION. After the wrestlers pass by they turn and face each other. The referee raises his hand forward between the two wrestlers. After a momentary pause to make certain the wrestlers are ready he blows his whistle and simultaneously drops his hand as a signal for the wrestlers to go into action.

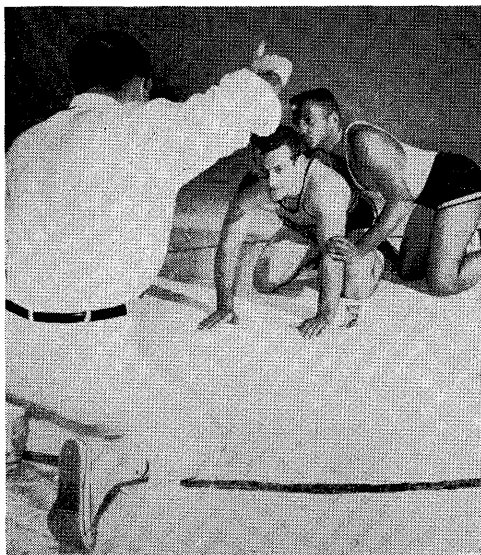

Fig. 4. (bottom left) RESUMING THE MATCH IN THE REFEREE'S POSITION ON THE MAT. The Referee should face the officials' table and kneel on one knee at a distance of 8 to 10 ft. in front of the wrestlers and a little to the side on which the top wrestler stations himself. The referee may give a preparatory command such as "get set" or "ready." When the wrestlers are in proper positions (Rule 8, Sec. 1) and after a momentary pause the referee blows his whistle and drops his hand to start the action. Note — Some wrestlers watch the referee's hand to get a fast start. It is usually better in such cases to blow the whistle a moment before dropping the hand. The whistle starts the action. The hand signal is for the timers in case they do not hear the whistle.

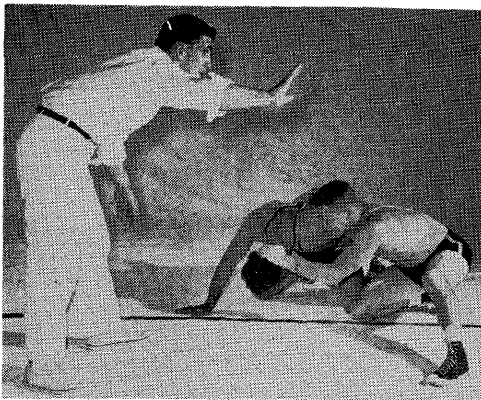

Fig. 5. (top left) STOPPING THE MATCH. The referee blows his whistle and raises his hand to stop the match. The arm and hand are extended with the palm of the hand directed toward the officials' table.



Fig. 6. (top right) STOPPING THE MATCH FOR OUT-OF-BOUNDS. When the contestants are out-of-bounds (Rule 8, Sec. 5) the referee stops the match as in Fig. 5. The referee indicates the position of the wrestlers and returns them to the center of the mat to resume wrestling.

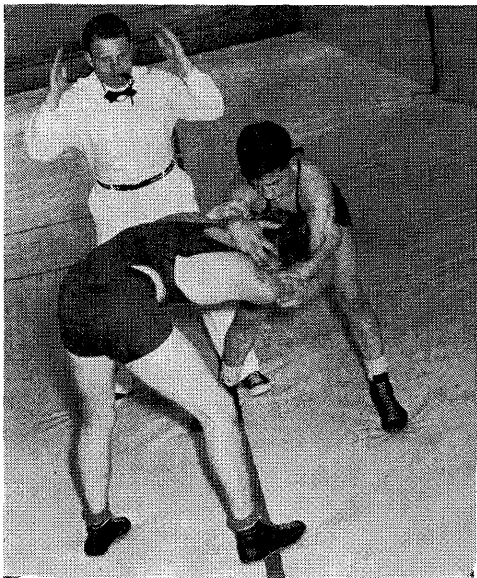

Fig. 7. (bottom left) DECLARING A NEUTRAL POSITION STANDING AFTER OUT-OF-BOUNDS. When the contestants are out-of-bounds (Rule 8, Sec 5 and 5a) and neither is in an advantage position, the referee stops the match as in Fig. 5 and signals a Neutral position. The upper arms are front horizontal, both forearms are vertical and the hands are extended upward. The referee places himself in the most advantageous position to determine the out-of-bounds and stops the match immediately when the out-of-bounds occurs.

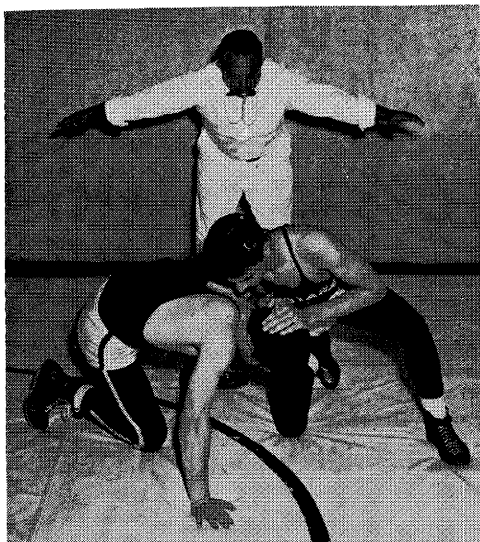

Fig. 8. (top left) INDICATING A NEUTRAL POSITION DURING A SCRIMMAGE FOR A TAKE-DOWN. Both arms are extended sideward slightly below the horizontal with the palms of the hands down. The referee moves his hands back and forth bringing them together and moving them away while verbally announcing "no advantage."

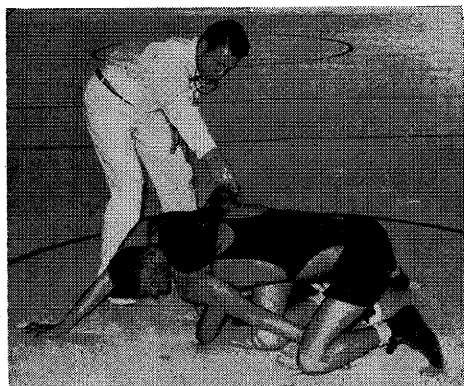

Fig. 9. (bottom left) INDICATING RETENTION OF ADVANTAGE. Whenever there is any doubt as to the contestant in the advantage position the referee should indicate the contestant in the advantage position by pointing to him with the index finger of one hand. The referee will keep his other hand down and along his leg so that there will be no confusion as to whether any points are awarded.

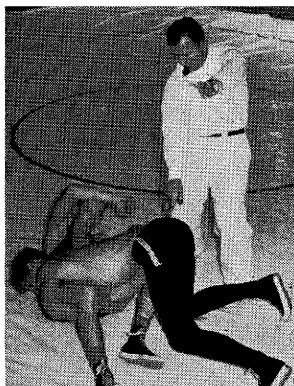

Fig. 10. (bottom right) AWARDED POINTS. One arm and index finger are pointed at the wrestler receiving the points. At the same time the referee verbally announces the award and the name of the team receiving it as he raises his opposite arm to a near vertical position indicating with extended fingers the number of points awarded.

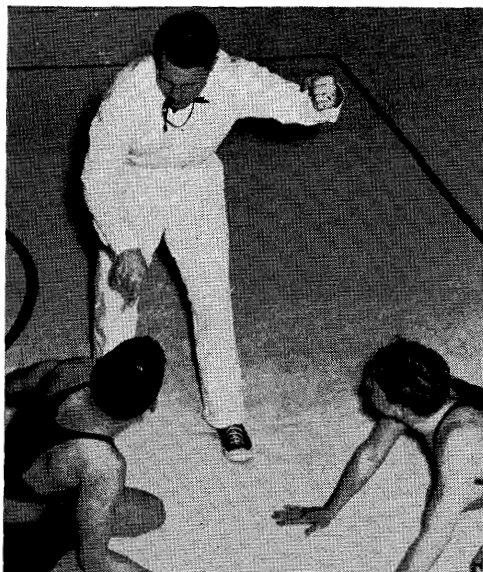

Fig. 11. (top left) WARNING A CONTESTANT FOR A VIOLATION. The match is stopped. The index finger of one hand is pointed to the violator. At the same time the referee verbally announces the penalty and raises the opposite arm with his fist doubled to indicate the "warning" penalty.

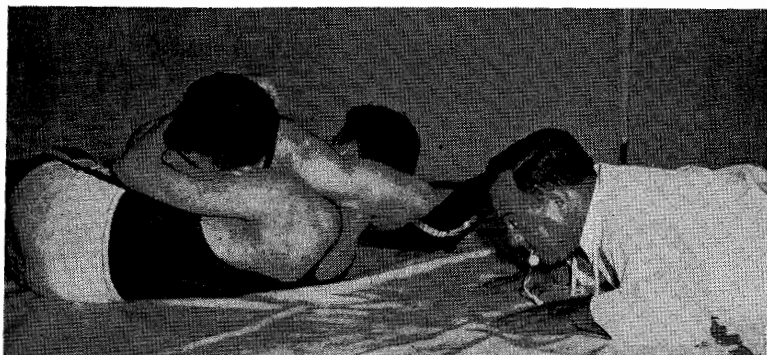

Fig. 12. (bottom) SCORING A PINNING SITUATION. The referee gets down on the mat in a prone position for the best view of the defensive contestant's back while at the same time trying to keep out of the way of the contestants. The referee does not signal a score for a "near-fall" or "predicament" until the pinning situation is ended. (Rule 8, Sec. 13, Note 1) He may indicate the extent of the situation by holding one hand behind his back with the fingers extended to indicate the points that will be awarded when the pinning situation is over. After the situation is finished the referee extends one arm upward indicating with the fingers the number of points awarded as he directs the index finger of his other hand toward the contestant receiving the points. (See Fig. 10.)

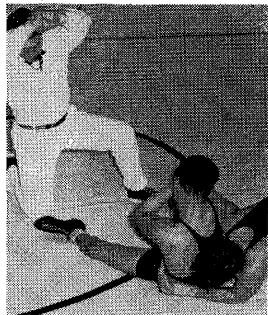
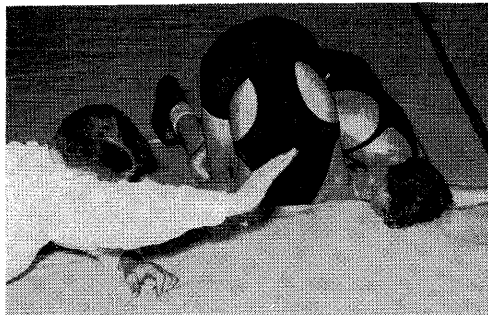

Fig. 13. (top left) CALLING A FALL. When the fall (Rule 8, Sec. 11) is imminent the referee raises one hand about 10 inches. As soon as the fall is completed he quickly strikes the mat with the palm and verbally announces "Fall." The referee is not to put his hands under the back of the defensive wrestler unless his view of the shoulders is blocked by one or both contestants and it is absolutely necessary for him to feel the back on the mat in order to call the fall (Rule 13, Sec. 14)

Fig. 14. (top right) INTERLOCKING HANDS, (Rule 10, Sec. 7a) OR GRASPING CLOTHING, (Rule 10, Sec. 7i) DURING AN ESCAPE MANEUVER. When the bottom contestant is in the process of an escape or reversal and the contestant on top locks his hands or grasps the clothing to prevent the maneuver, the referee indicates the violation by grasping the wrist of one hand with his other hand and holding it over his head. This signal stops the advantage time for the top contestant, and indicates the violation has occurred but the referee is allowing the bottom contestant an opportunity to complete the action providing he does so in one continuous maneuver. If the maneuver is successful (bottom contestant gains neutral or top position) the referee signals the points and the match continues with no interruption. If the bottom contestant fails to complete the maneuver the referee stops the match and awards the penalty. (See Penalty Chart)



Fig. 15. (bottom left) PREVENTING AN ILLEGAL OR POTENTIALLY DANGEROUS HOLD. (Rule 16, Sec. 6 & Rule 13, Sec. 13) The referee anticipates a potentially dangerous hold and gets in position to block it before it becomes dangerous. He may also verbally caution the contestant against forcing a potentially dangerous hold into an illegal hold.

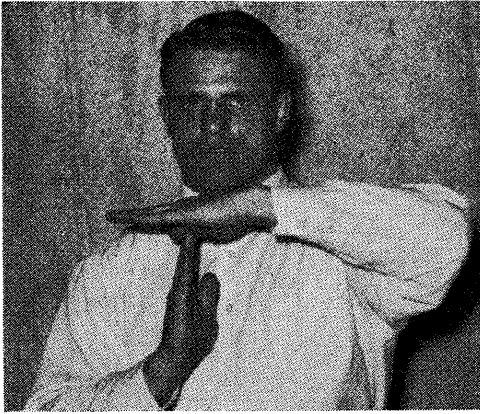

Fig. 16. (top left) CALLING TIME OUT. The match is stopped as in Figure 5. If there is to be a delay in resuming the match, the referee will indicate "time-out" by extending one hand in a vertical position at right angles to his chest with the ends of the fingers touching the palm of the other hand which is extended in a horizontal position in front of the chest. The referee announces to the scorers the reason for the time out and to whom it is charged.

Fig. 17. (center right) DECLARING THE WINNER. (Rule 13, Sec. 17) At the end of the match the referee orders the wrestlers to shake hands and raises the hand of the winner.

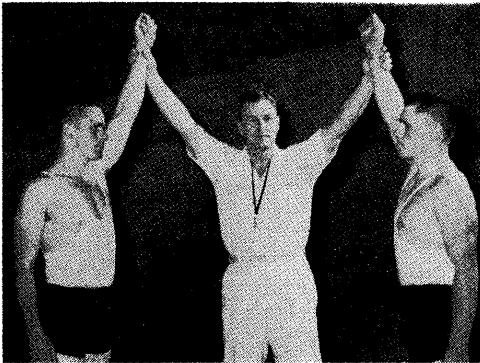
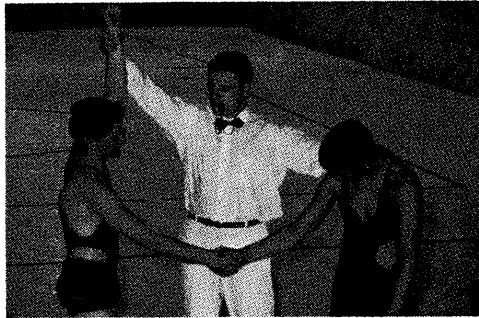

Fig. 18. (bottom left) DECLARING A DRAW. In case of a tie score at the end of the match in dual meets the referee will raise a hand of each of the contestants after they shake hands.

Supplementary Modifications for Interscholastic Wrestling

The NCAA Rules shall apply with the following exceptions :

1. **Eligibility.** Contestants shall be eligible under the rules of the High School Athletic Association of the State in which their school is located.

2. **Weight Classification.** Competition shall be divided into weight classes as follows :

103 lbs.	127 lbs.	145 lbs.	165 lbs.
112 lb.	133 lbs.	154 lbs.	Unlimited.
120 lbs.	138 lbs.		

Beginning January 1st and continuing until February 1st, two additional pounds will be allowed in each weight class. Beginning February 1st and continuing for the remainder of the season, one additional pound shall be allowed in each weight class. This will make a net increase of three pounds beginning the 1st of February.

Additional weight classes may be officially included in the weight classification provided they are adopted by the individual state athletic associations. Interstate dual meets shall be contested in the original 10 weights.

3. Weighing In of Contestants.

A. **DUAL MEETS.** Contestants may weigh in a maximum of one hour and a minimum of one half-hour before time the meet is scheduled to begin. (By mutual consent of the competing schools the college regulations may be followed.)

B. **TOURNAMENTS.** Each day of the tournament, contestants may weigh in a maximum of five hours and a minimum of one hour before the meet is to begin, with one pound allowance to be given each day over the weight limit of the previous day.

Note. Changes in weighing in time may be made by the individual state associations.

4. Length of Matches.

A. **DUAL MEETS.** These matches shall be six minutes in length divided into three periods of two minutes. No rest is allowed. These matches shall be conducted in the same manner as set forth in Rule 7 and Rule 8, Section 14.

B. **TOURNAMENT.** These matches shall consist of three periods of two minutes each, conducted in the same manner as third-place matches under Rule 7, Sec. 5. If a match results in a tie, it shall be decided in accordance with Rule 7, Sec. 4, except the overtime shall consist of *two one-minute periods*.

C. No contestant shall be required to wrestle two matches in any tournament with less than a one (1) hour rest between such matches.

5. **Illegal Holds.** In addition to the illegal holds barred in Rule 10, the double wristlock and all headlocks without the arm or leg included are illegal.

A. **ILLEGAL DOUBLE WRISTLOCKS.** The double wristlock shall be interpreted as any grapevine or wrap-around of the arm with two hands on the opponent's wrist or one hand on the opponent's wrist and the other hand on the wrestler's own wrist. The key lock is not to be interpreted as a double wristlock.

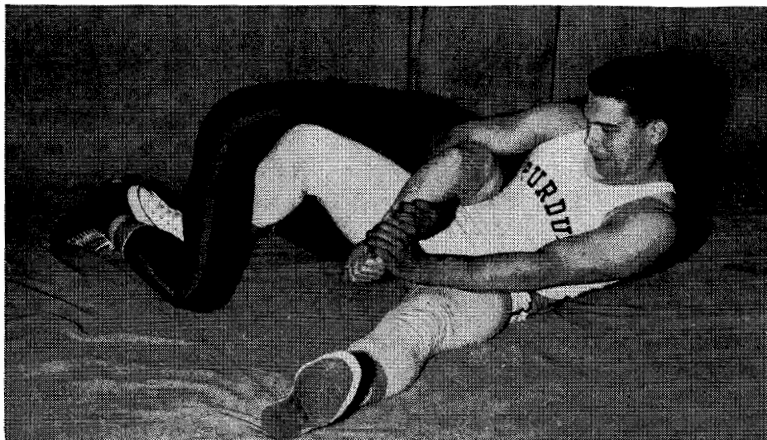

No. 24—ILLEGAL DOUBLE WRIST LOCK

Two hands on opponent's wrist.

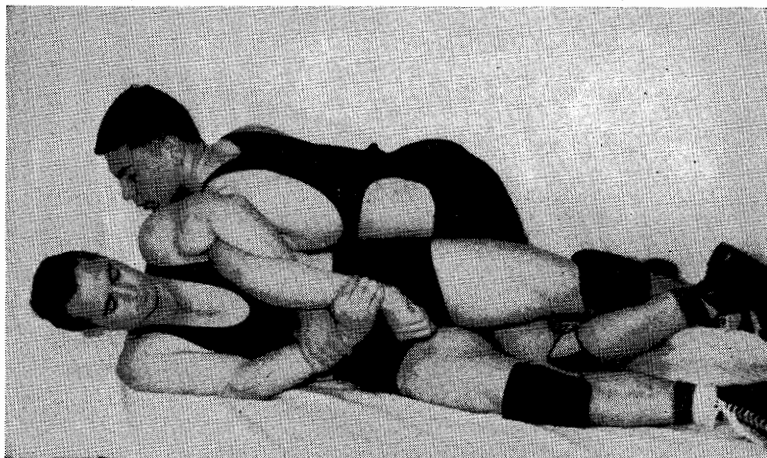

No. 25—ILLEGAL DOUBLE WRIST LOCK

One hand on opponent's wrist and one hand on own wrist.

B. ILLEGAL HEADLOCK. An illegal headlock shall be interpreted as locking or overlapping the hands or arms around an opponent's head or neck without including the opponent's arm or leg in the ho'd.

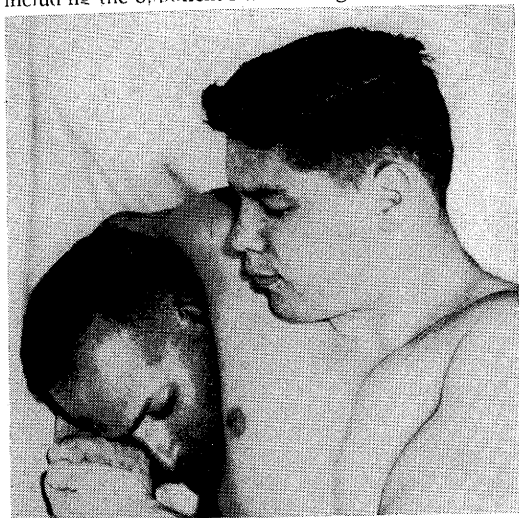

No. 26—ILLEGAL HEAD
LOCK

*Locking the arm around the
head.*

No. 27—LEGAL HEAD
LOCK

*Opponent's arm is included
in the lock.*



C. ILLEGAL GUILLOTINE. If the wrestler locks or overlaps his hands or arms around his opponent's head in securing this hold and the opponent's arm is not included with the head, this is an illegal hold.



No. 28—ILLEGAL GUILLOTINE

Arm is locked around opponent's head.

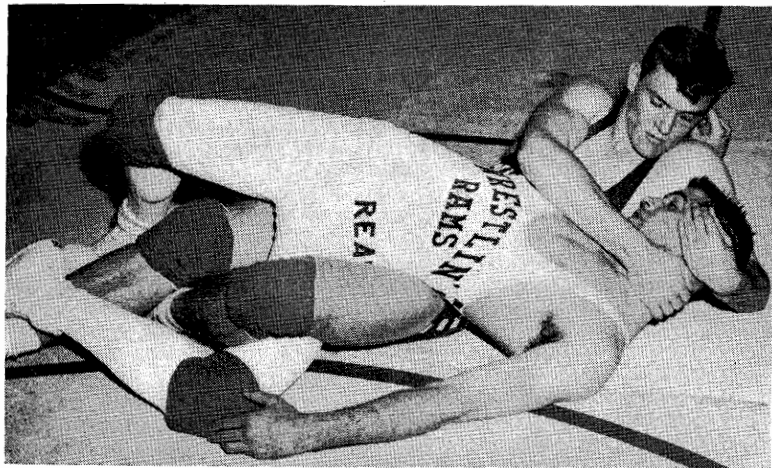

No. 29—LEGAL GUILLOTINE

Hands are not locked or overlapped around head.

CHAMPIONSHIP WRESTLING

BY

CLIFF KEEN CHARLIE SPEIDEL RAY SWARTZ

This is THE book on amateur wrestling! For beginners, advanced wrestlers, Olympic candidates, coaches and instructors. 223 pages packed with detailed information. 300 step-by-step photographs. Latest coaching methods. An entire chapter devoted to Olympic free-style, with tips on foreign techniques and counters for them. Compiled and edited by the wrestling coaches of the University of Michigan, Pennsylvania State University, and the United States Naval Academy, for the V-Five Association of America.

EQUIPMENT AND FACILITIES • CARE AND PREVENTION OF INJURIES • DEVELOPING A TEAM FOR INTRAMURALS • TAKE DOWNS • GO BEHINDS • TAKING TO MAT FROM STANDING • CONTROLS, BREAK-DOWN, AND RIDES • PINNING COMBINATIONS • ESCAPES FROM UNDERNEATH • ESCAPES FROM STANDING • BLOCKS, BREAKS, AND COUNTERS • OLYMPIC FREE-STYLE • CLASS INSTRUCTION METHODS

Based upon 91 years of combined coaching experience, this is the most comprehensive manual on wrestling that has ever been compressed into one volume. Sturdily bound in tan cloth with an attractive dust jacket.

ONLY
\$4.50

AT YOUR BOOKSELLER OR

THE U. S. NAVAL INSTITUTE

ANNAPOLIS, MARYLAND

(Educational discount on quantity orders)

Recognized by top experts in all sports

Wilson provides the world's
finest equipment for Football,
Basketball, Baseball, Golf,
Tennis—all sports!

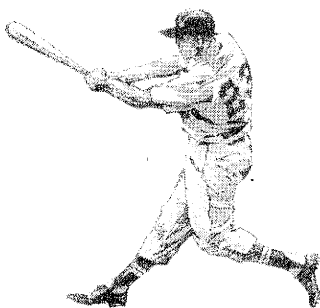
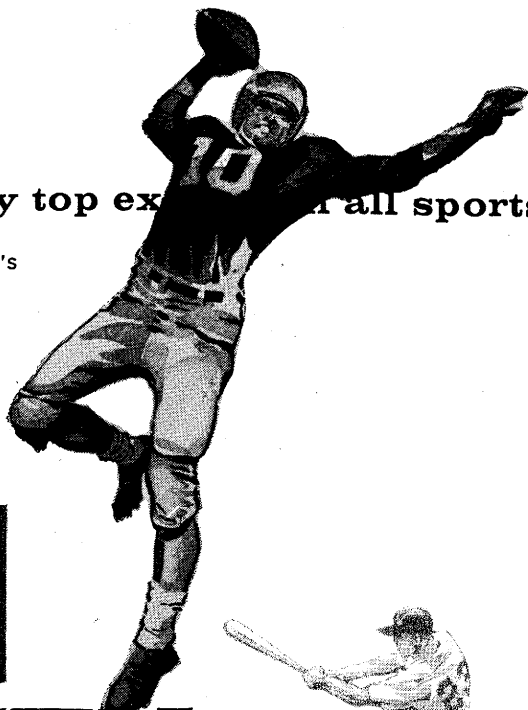

**WIN
WITH
WILSON**

WILSON SPORTING GOODS CO., CHICAGO, ILLINOIS

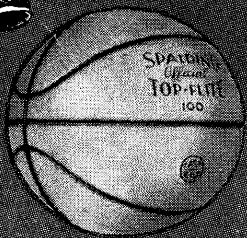
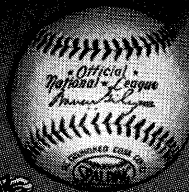
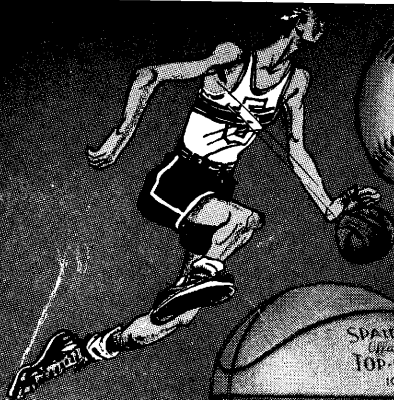

SPALDING

TEAM EQUIPMENT
THAT IS
OFFICIAL WITH AMERICA

